

WALTON



UNIVERSITY OF
ARKANSAS

Quarterly Business Analysis

Mervin Jebaraj, Director
Center for Business and Economic Research
June 4, 2026

Twitter: @MervinJebaraj
Slides: cber.uark.edu

Real GDP Growth 2019 Q1 - 2026 Q1

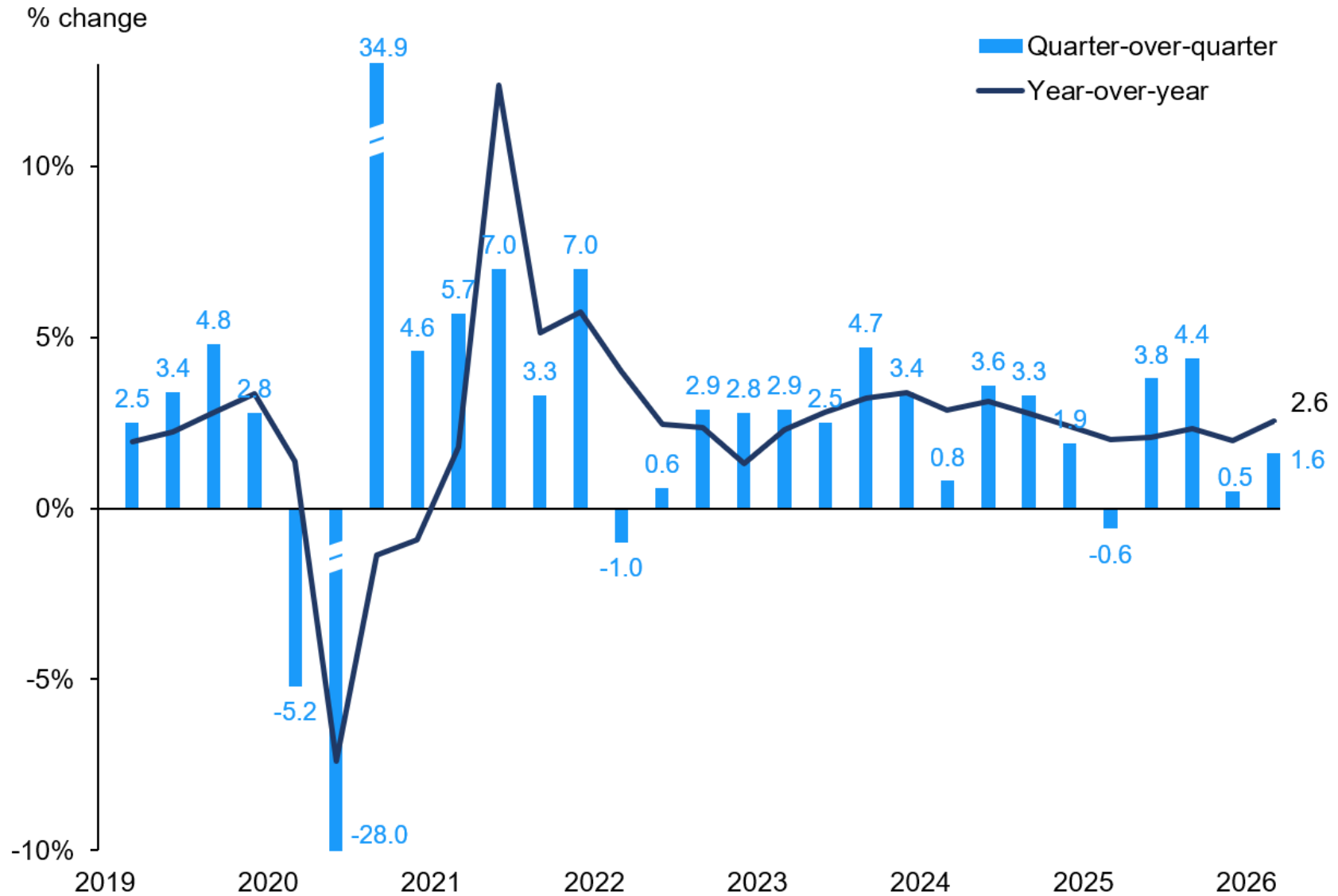

Source: BEA, EY-Parthenon



Contributions to US Real GDP Growth

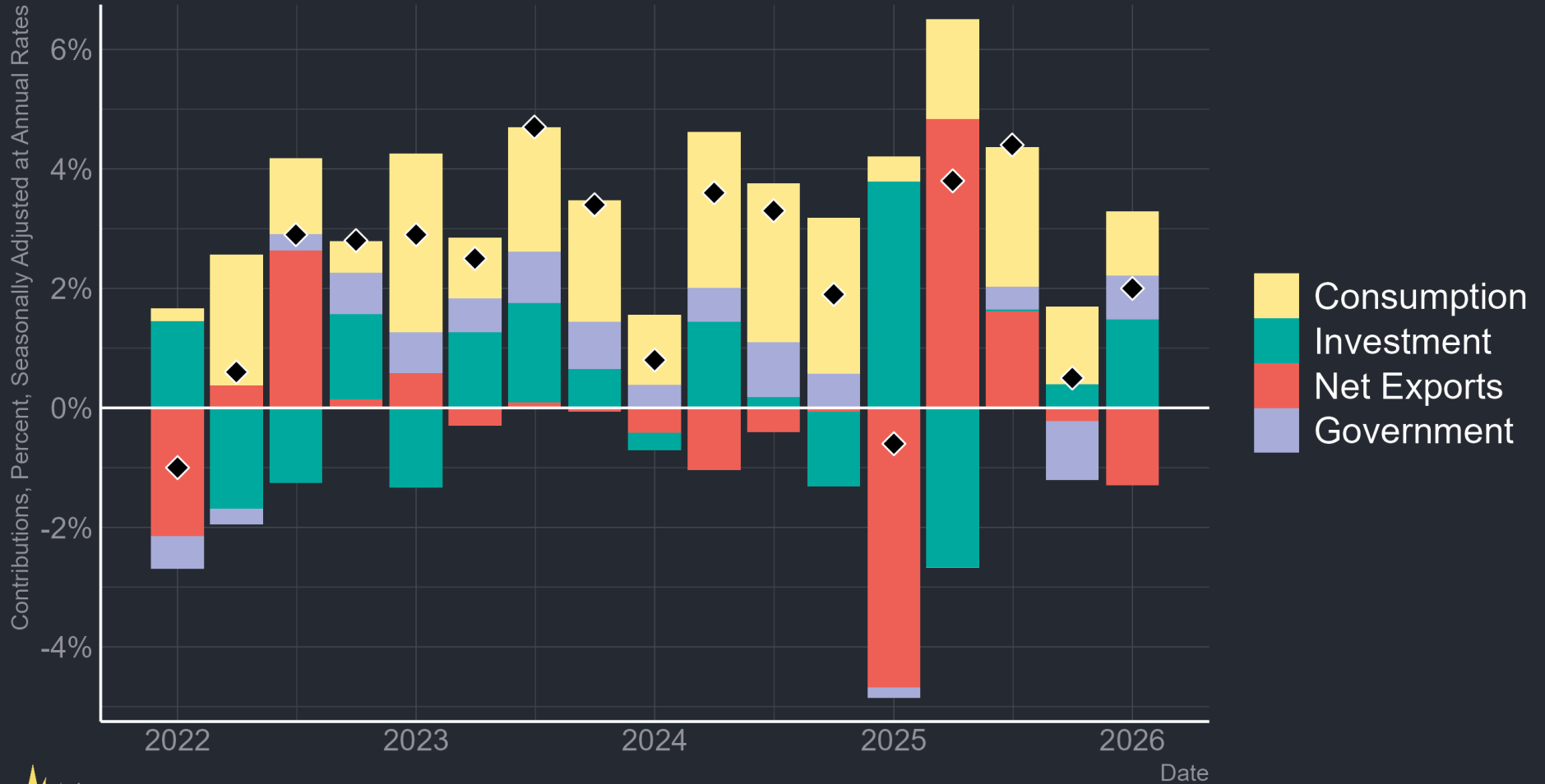

Graph created by @JosephPolitano using BEA data



FRED

● Real final sales to private domestic purchasers

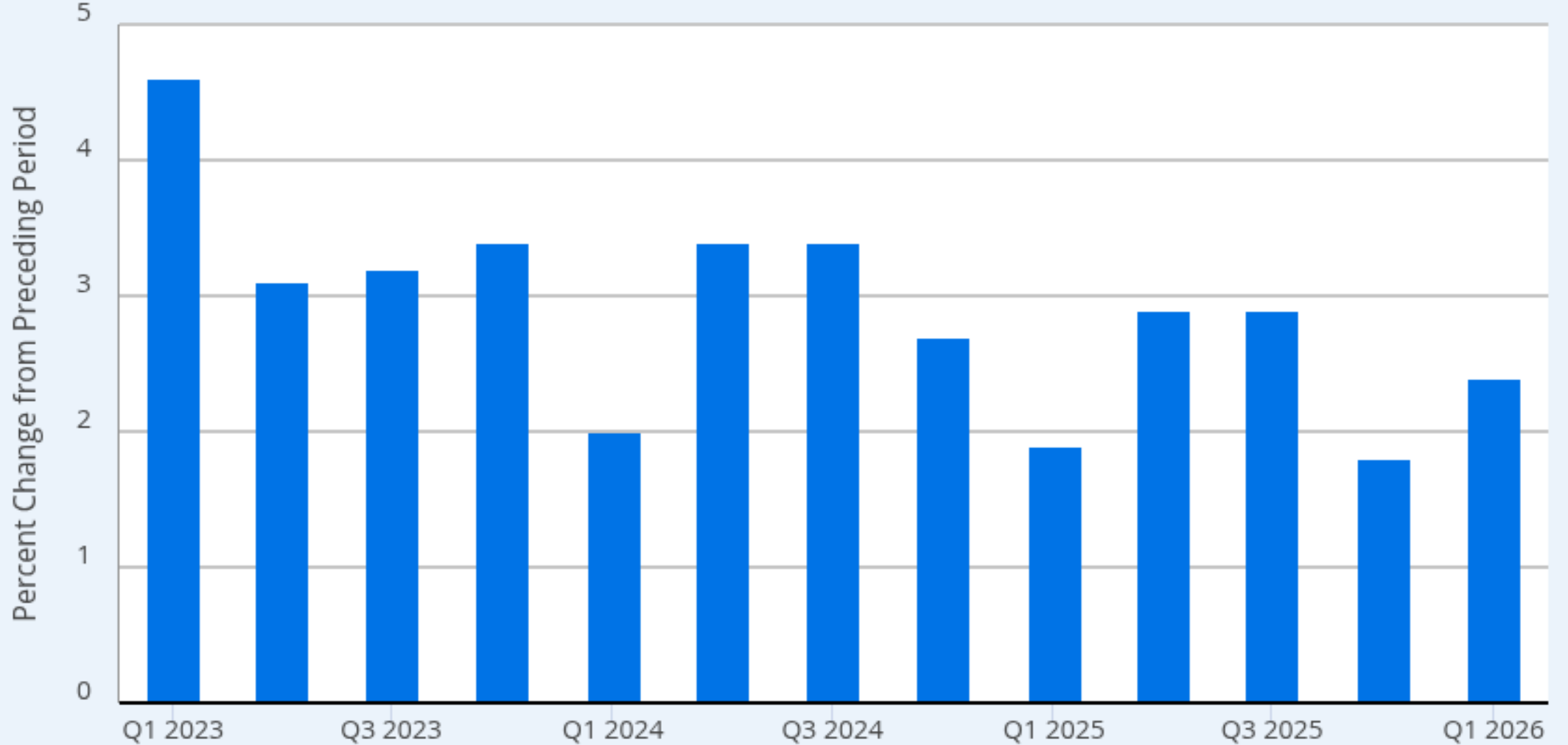

Source: U.S. Bureau of Economic Analysis via FRED®

Shaded areas indicate U.S. recessions.

myf.red/g/1WKlv



FRED

● Real Private Nonresidential Fixed Investment

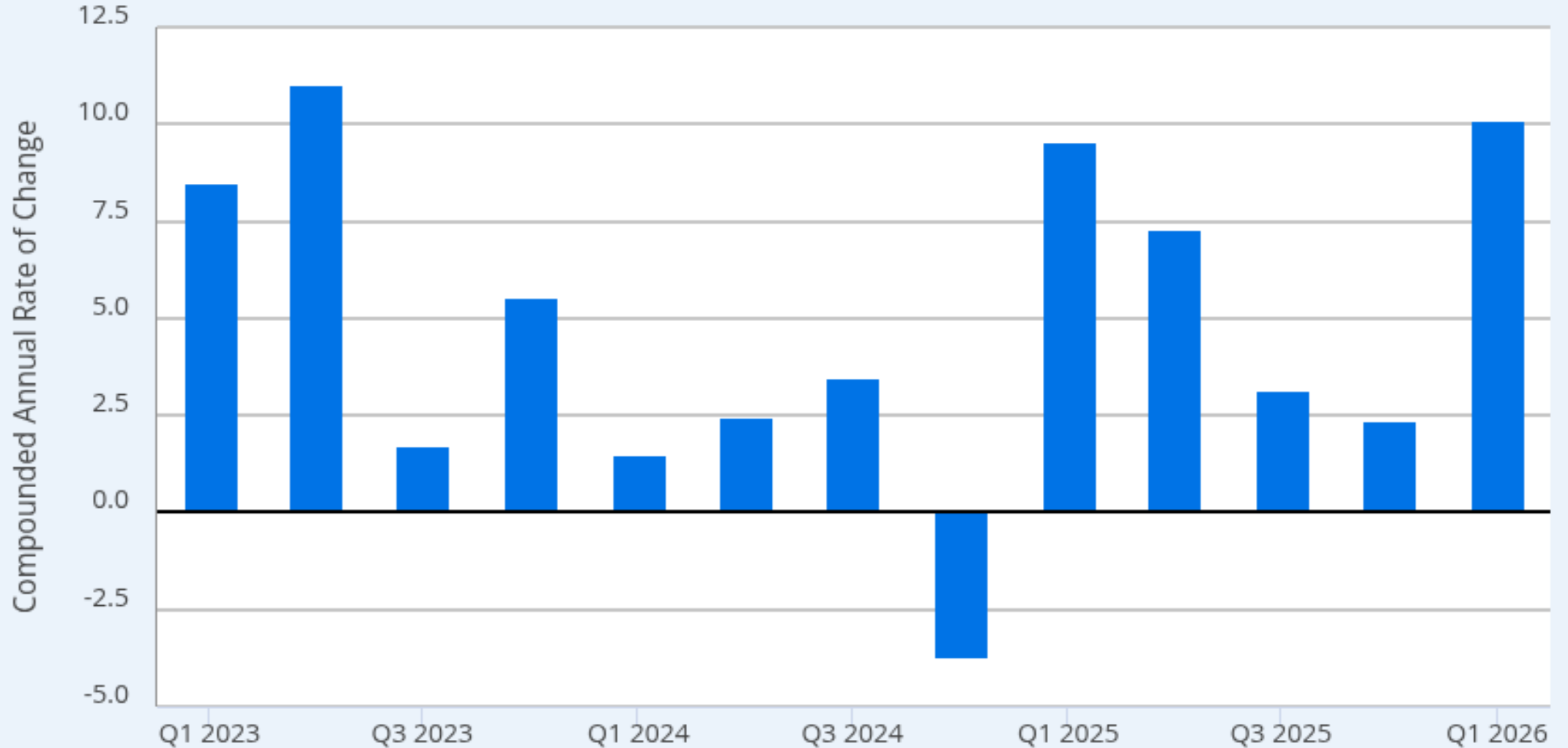

Source: U.S. Bureau of Economic Analysis via FRED®

Shaded areas indicate U.S. recessions.

myf.red/g/1WKm8



FRED

— Private fixed investment in information processing equipment and software

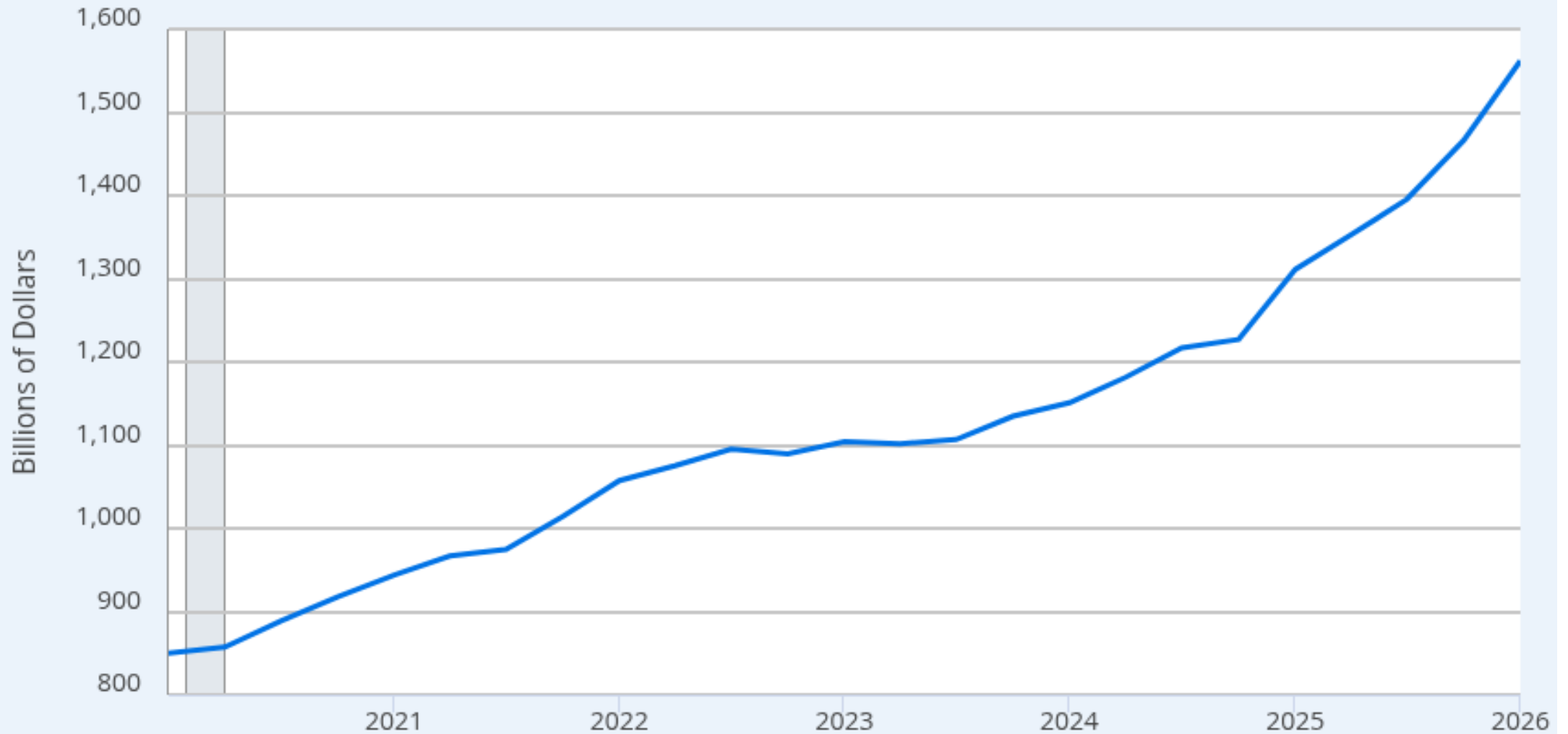

Source: U.S. Bureau of Economic Analysis via FRED®

Shaded areas indicate U.S. recessions.

myf.red/g/1WKkZ



Booking Pace Sentiment Below Expectations By Market

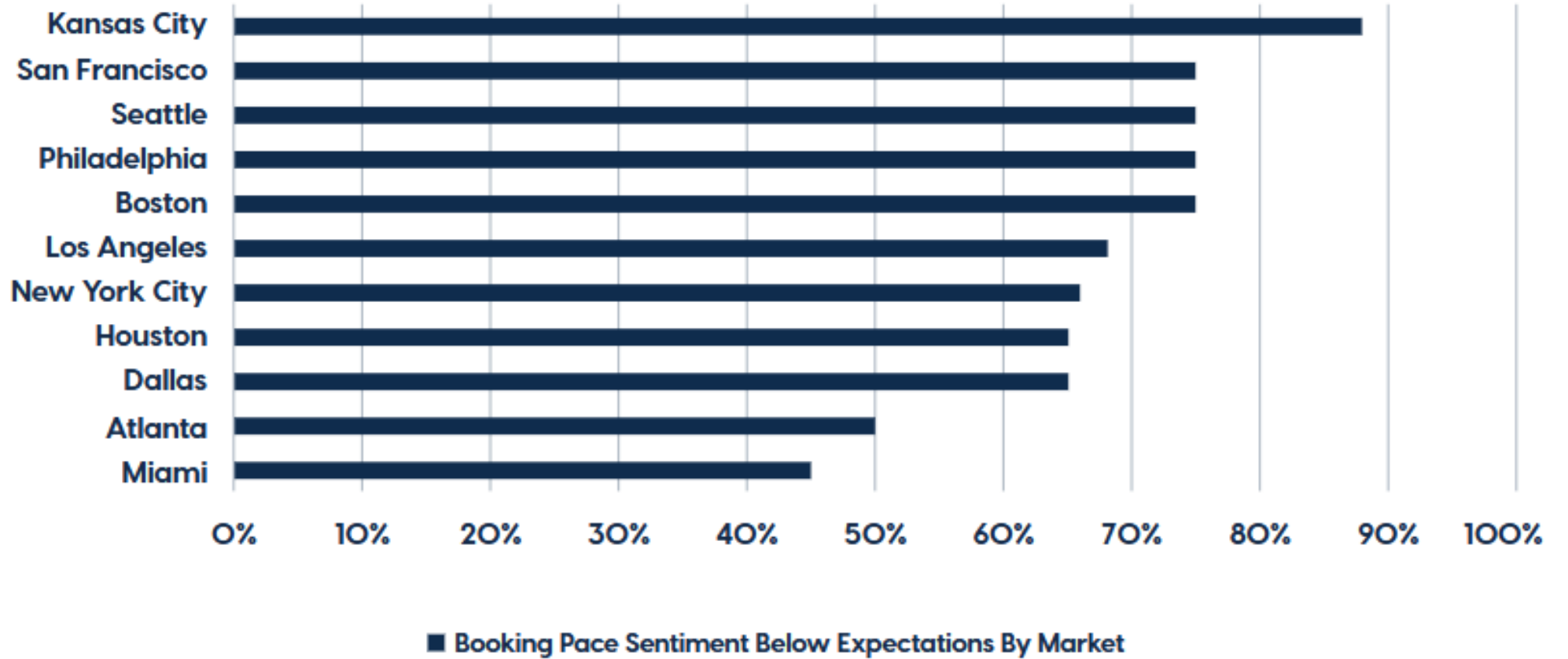



Month-over-month change in total nonfarm employment

January 2021 - April 2026

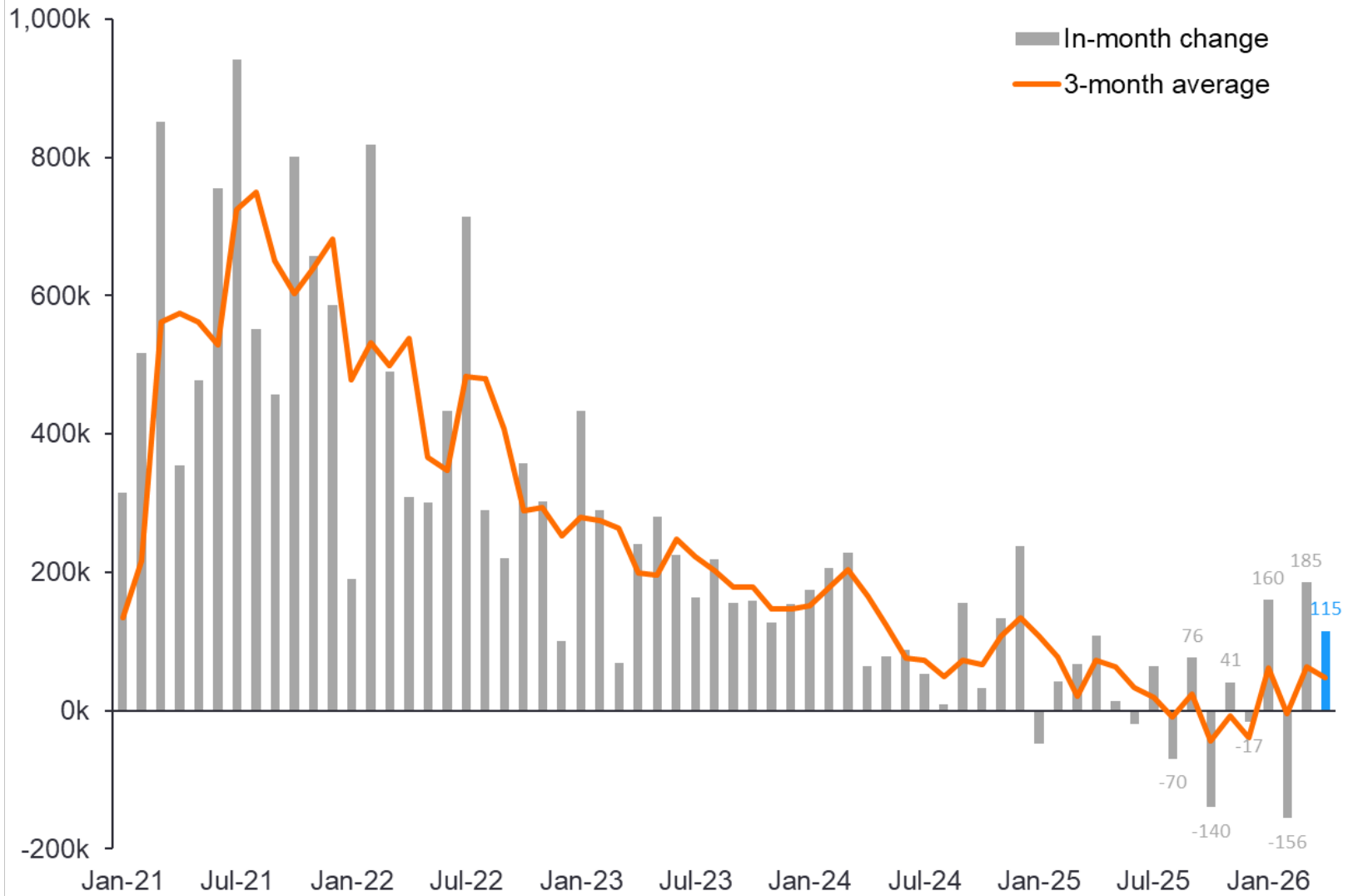

Source: BLS; EY-Parthenon

JOLTS openings, quits and hirings rate

January 2010 - April 2026

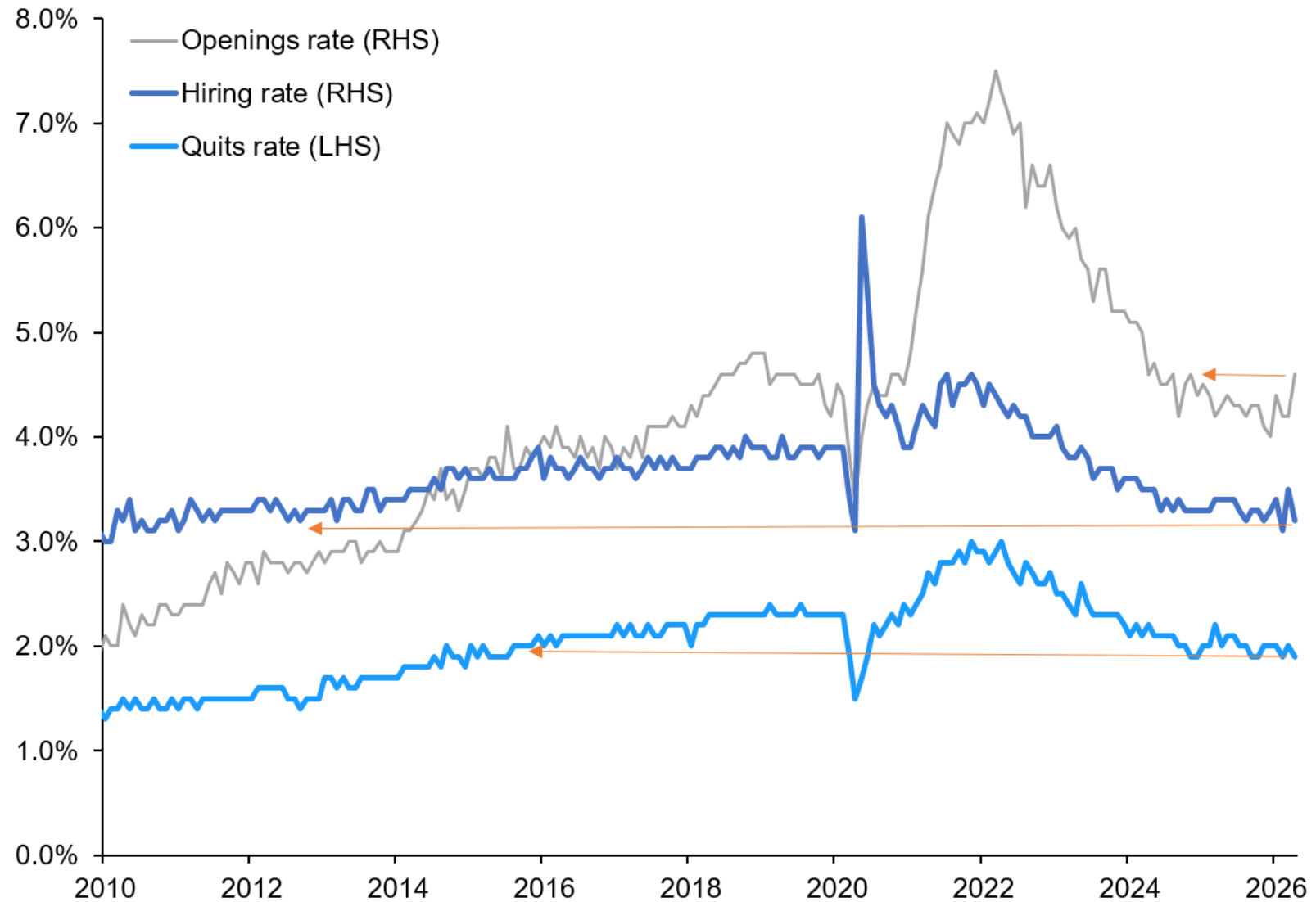

Source: BLS; EY-Parthenon

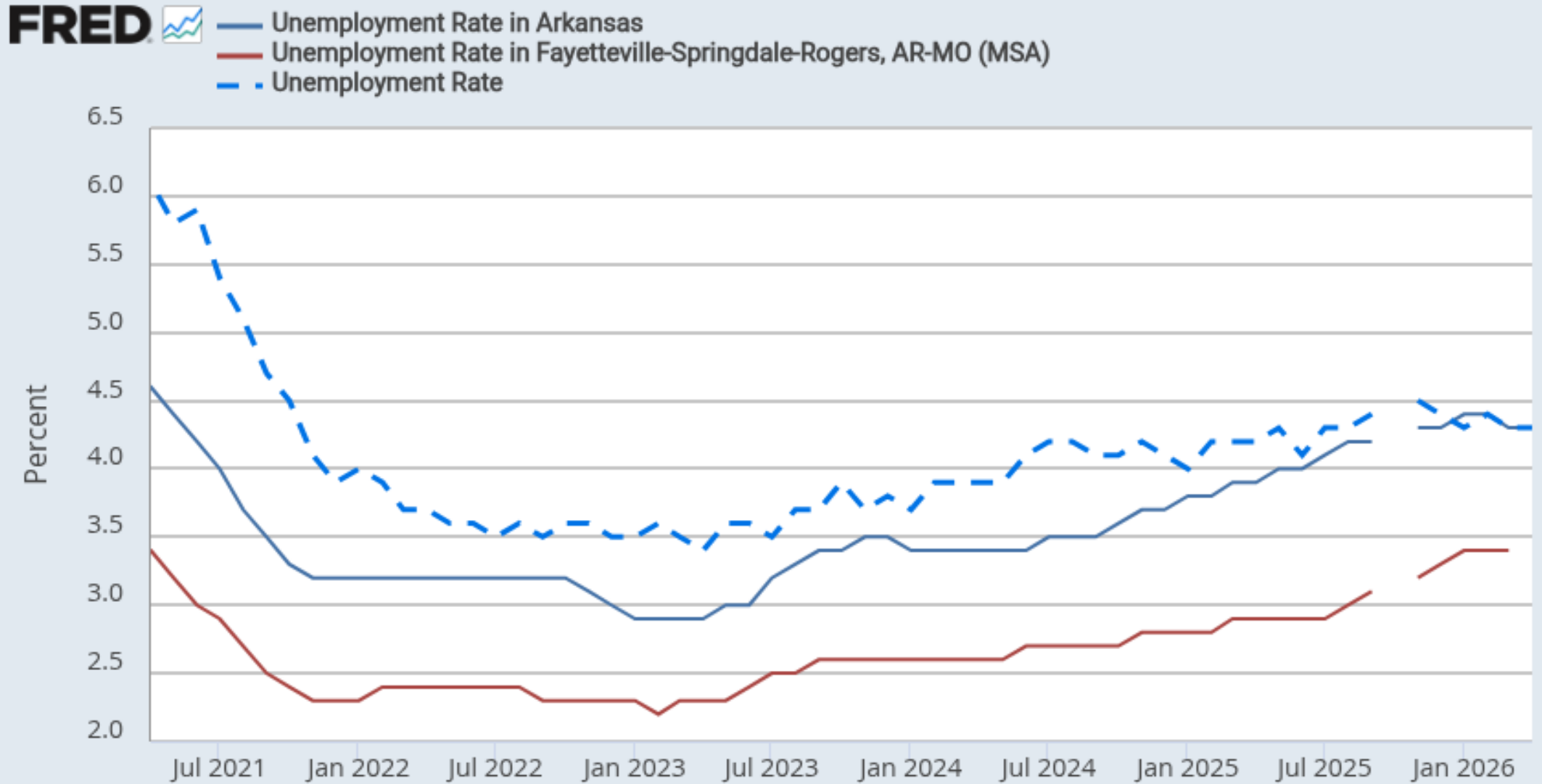

Source: U.S. Bureau of Labor Statistics via FRED®

Shaded areas indicate U.S. recessions.

myf.red/g/1WKol



US monthly payroll change April 2026

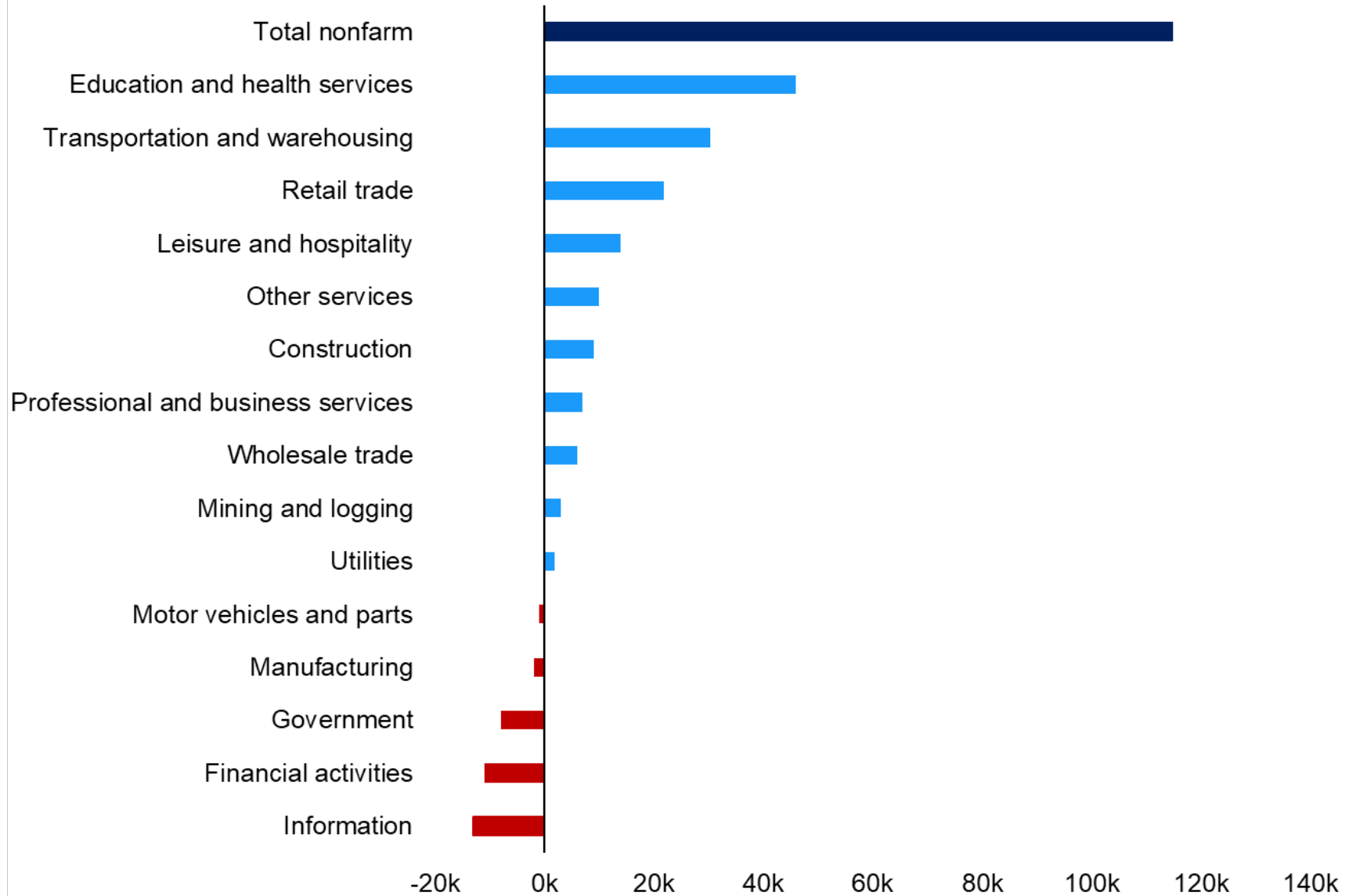

Source: BLS; EY-Parthenon



Arkansas Change in Employment by Sector, 2025-26

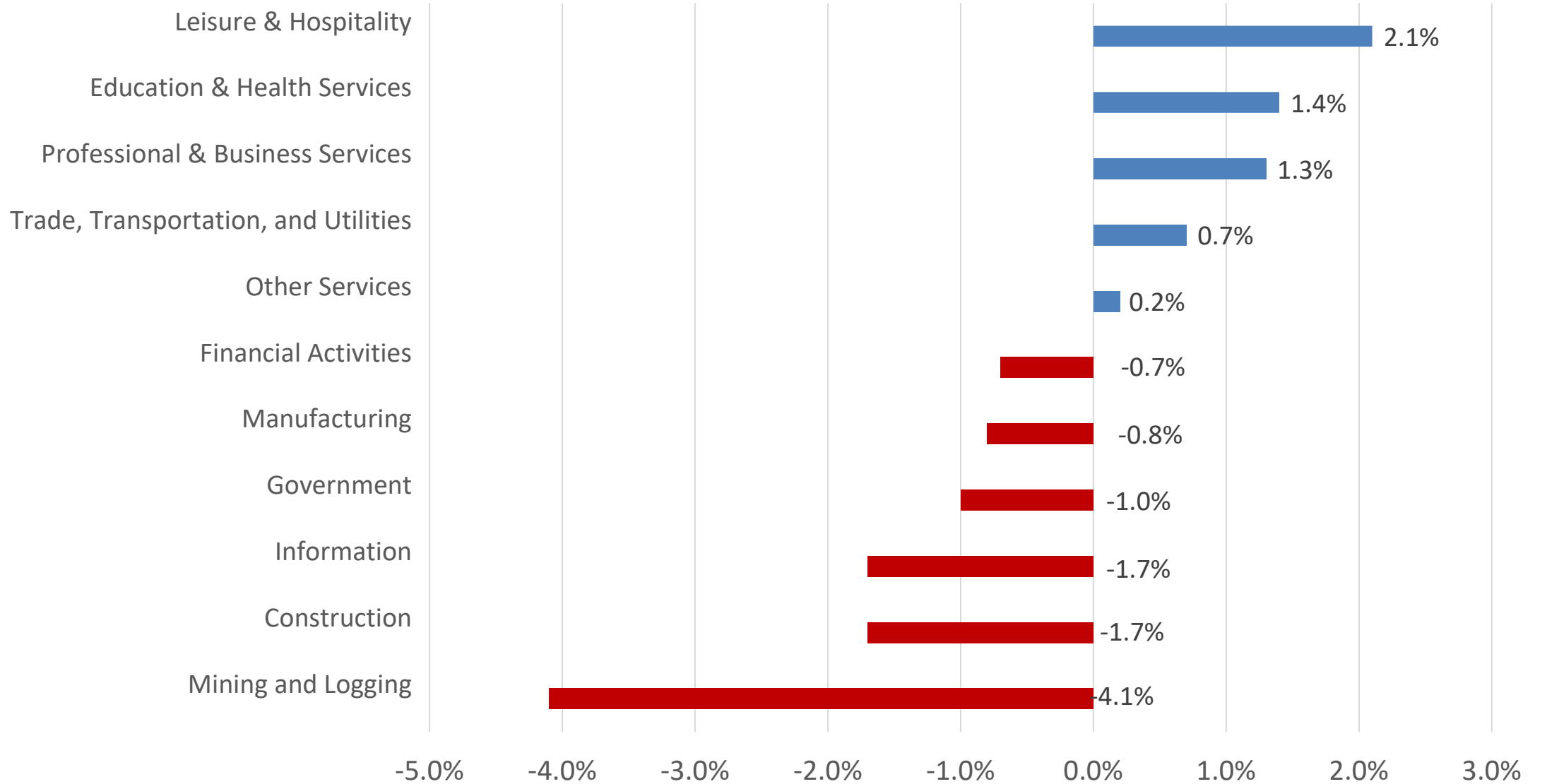

Source: Bureau of Labor Statistics

Northwest Arkansas Change in Employment by Sector, 2025-26

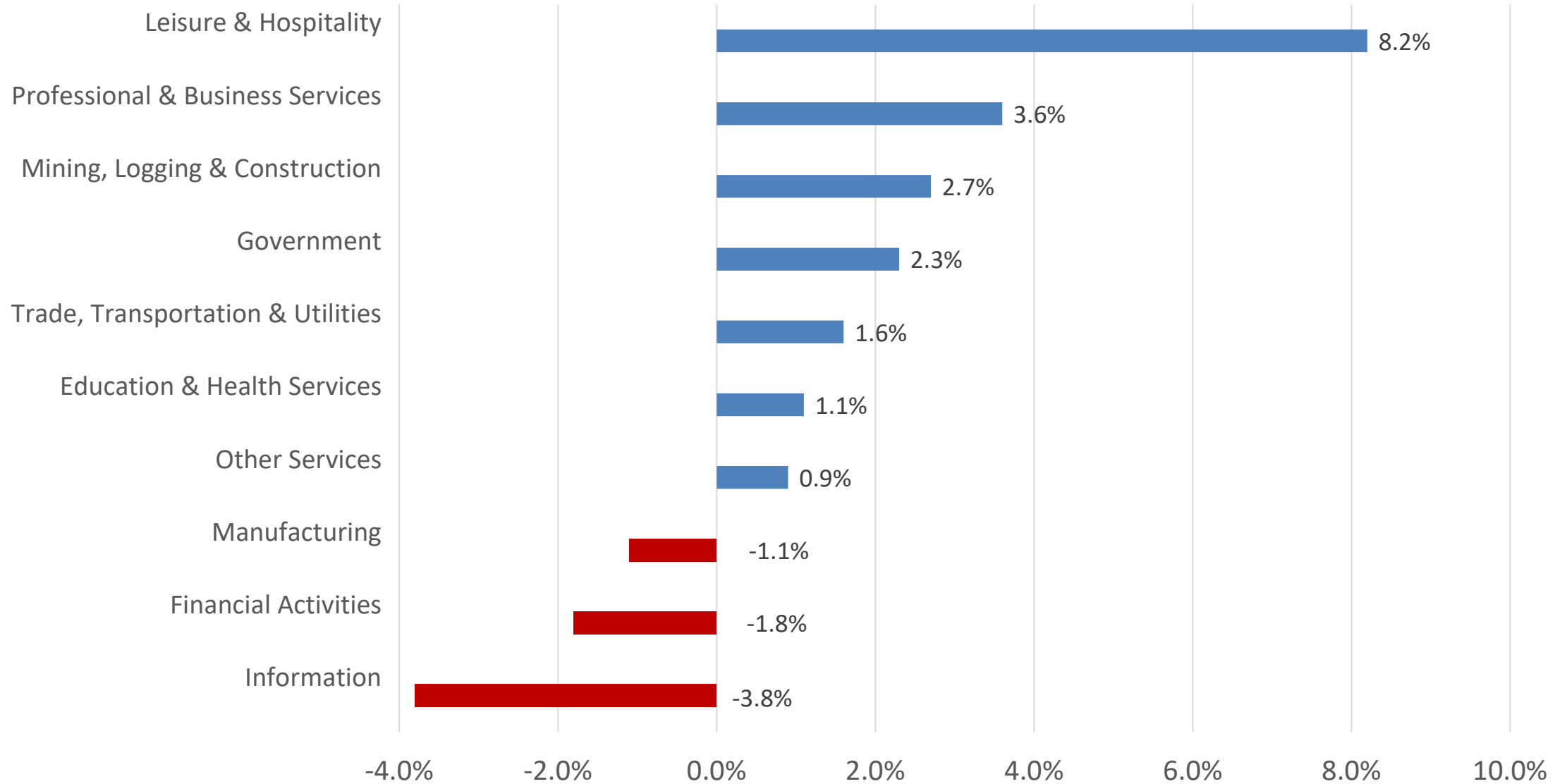

Source: Bureau of Labor Statistics



Labor force participation rate

January 1980 - April 2026, Seasonally adjusted

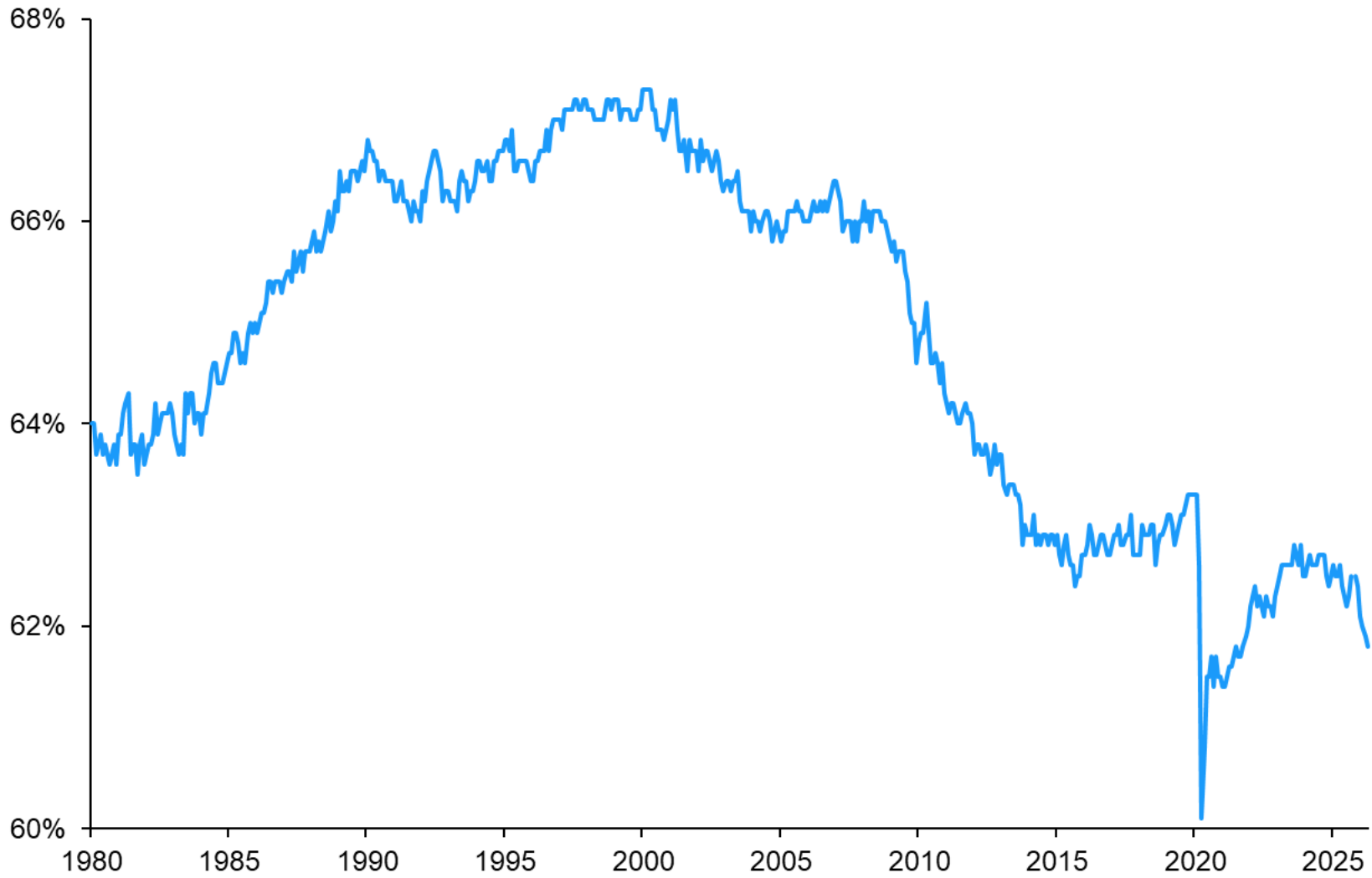

Source: BLS; EY-Parthenon



Labor force participation rates

January 1990 - April 2026, Seasonally adjusted

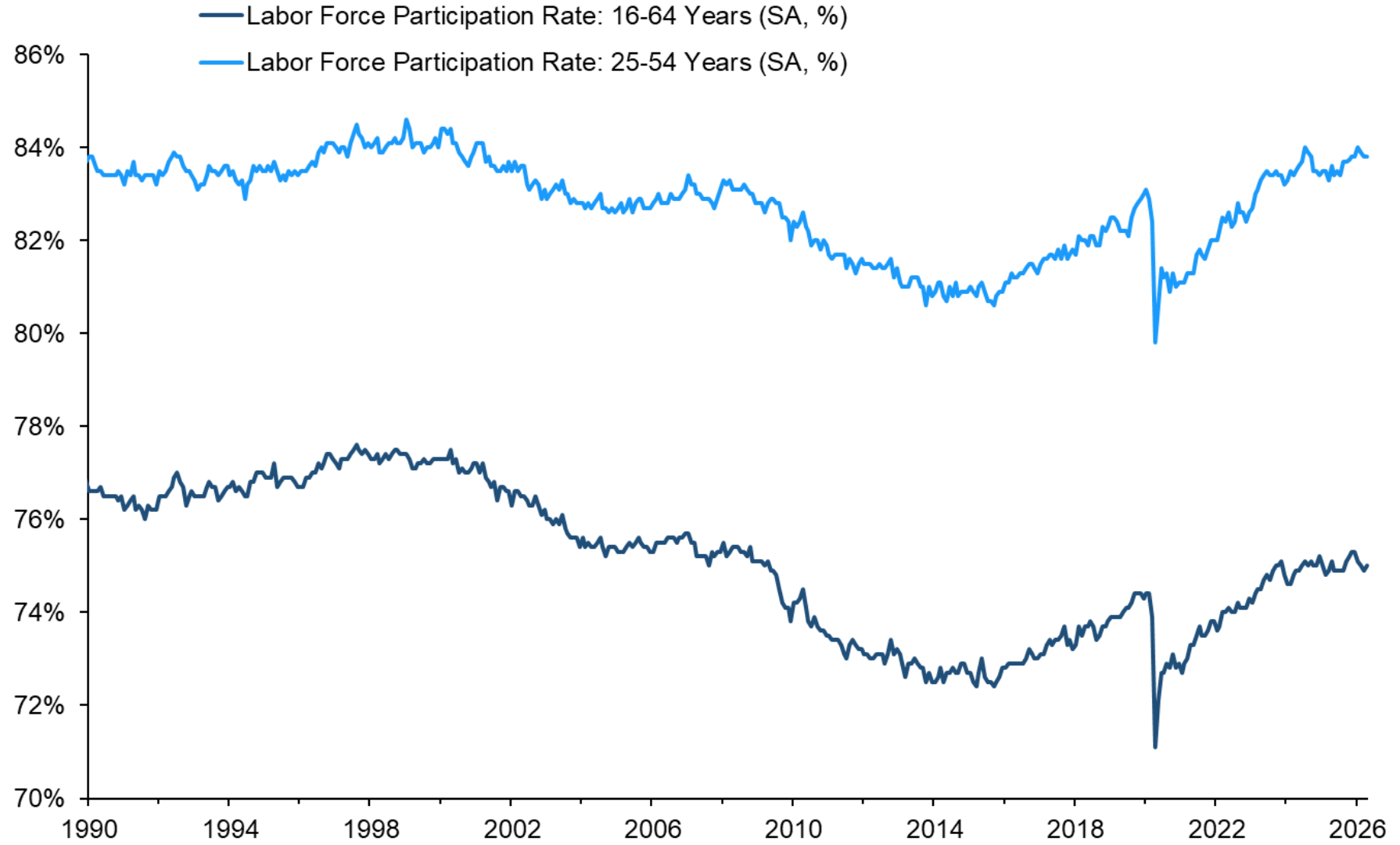

Source: BLS; EY-Parthenon



FRED

— Unemployment Rate - High School Graduates, No College, 20 to 24 years
- - Unemployment Rate - College Graduates - Bachelor's Degree, 20 to 24 years

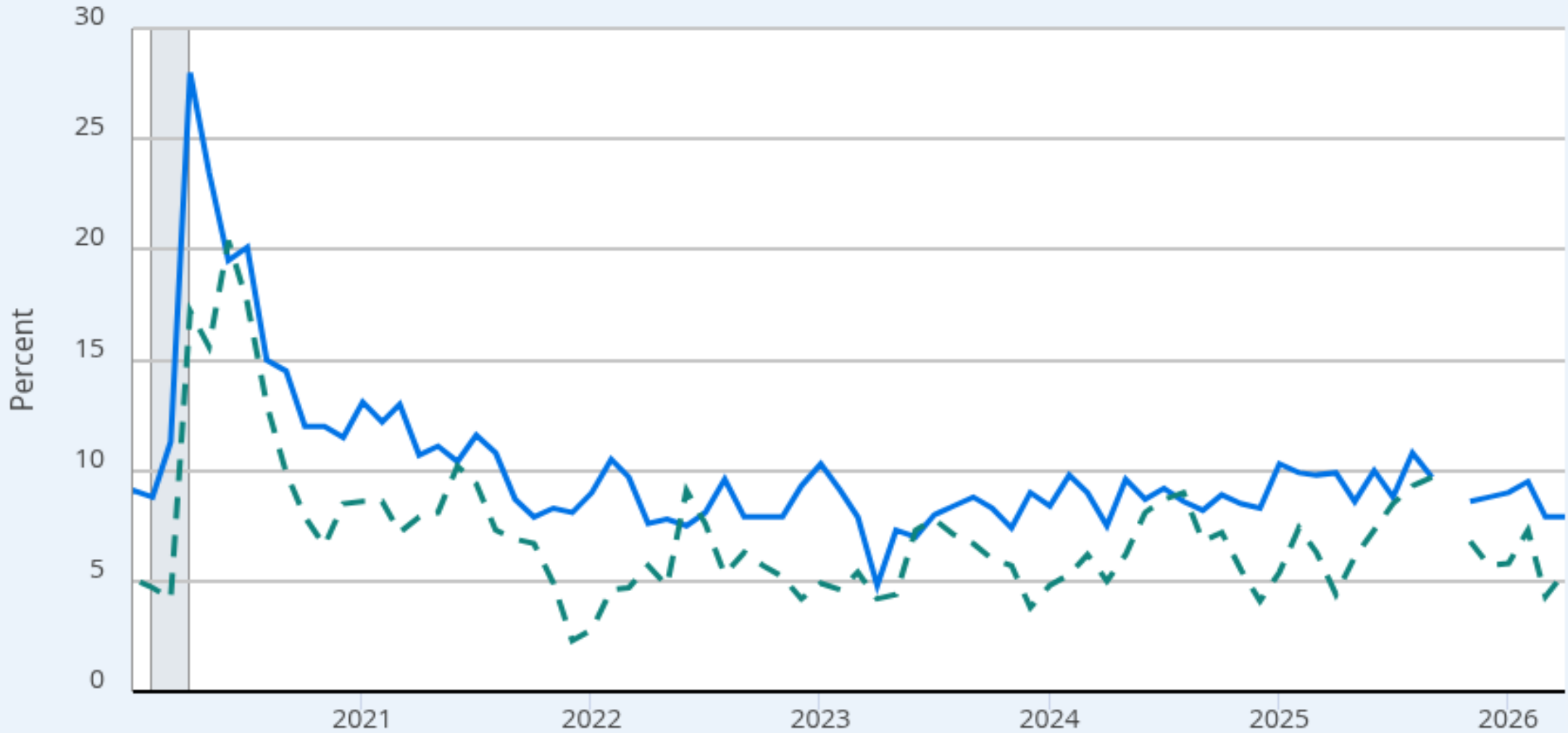

Source: U.S. Bureau of Labor Statistics via FRED®

Shaded areas indicate U.S. recessions.

myf.red/g/1WKq1

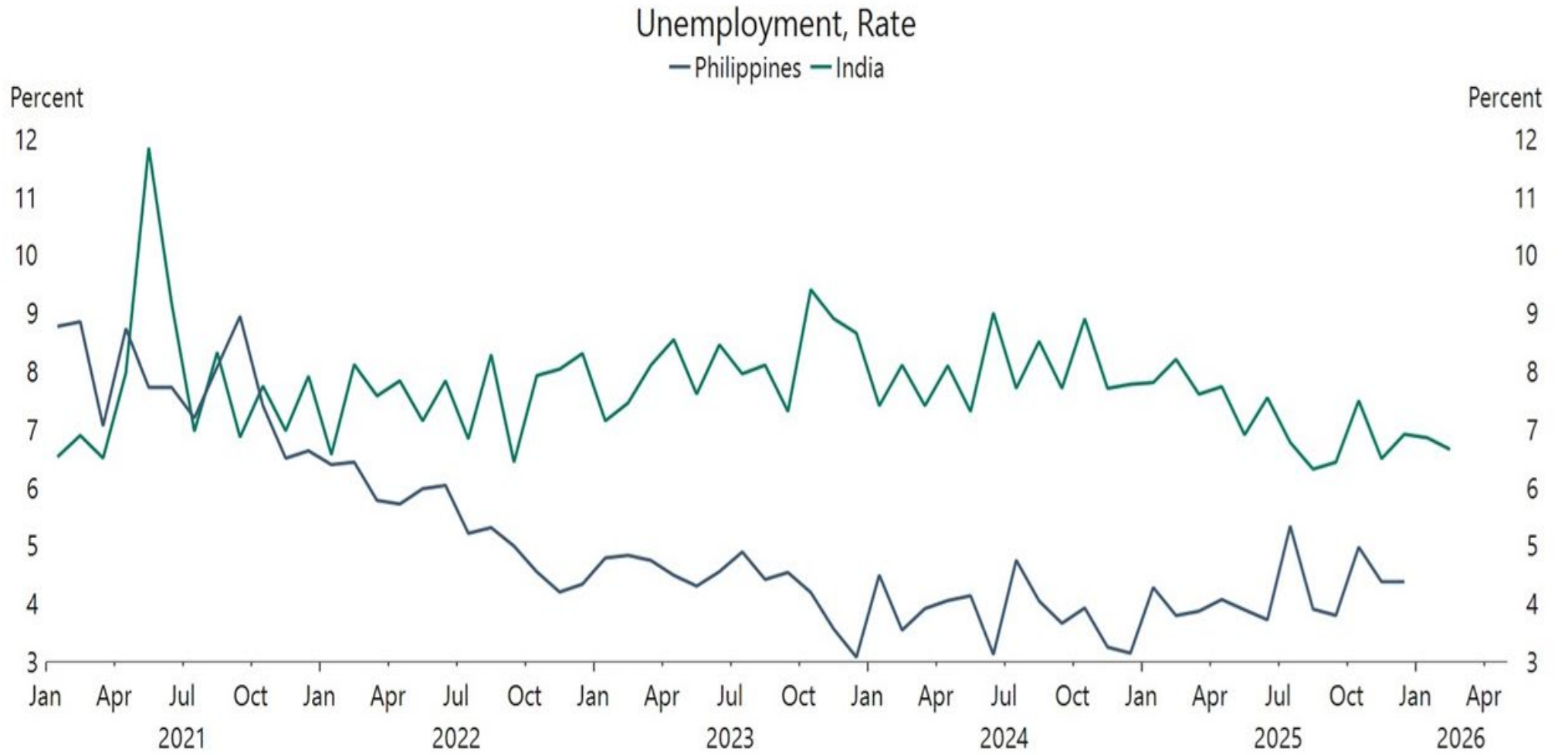

Source: Apollo

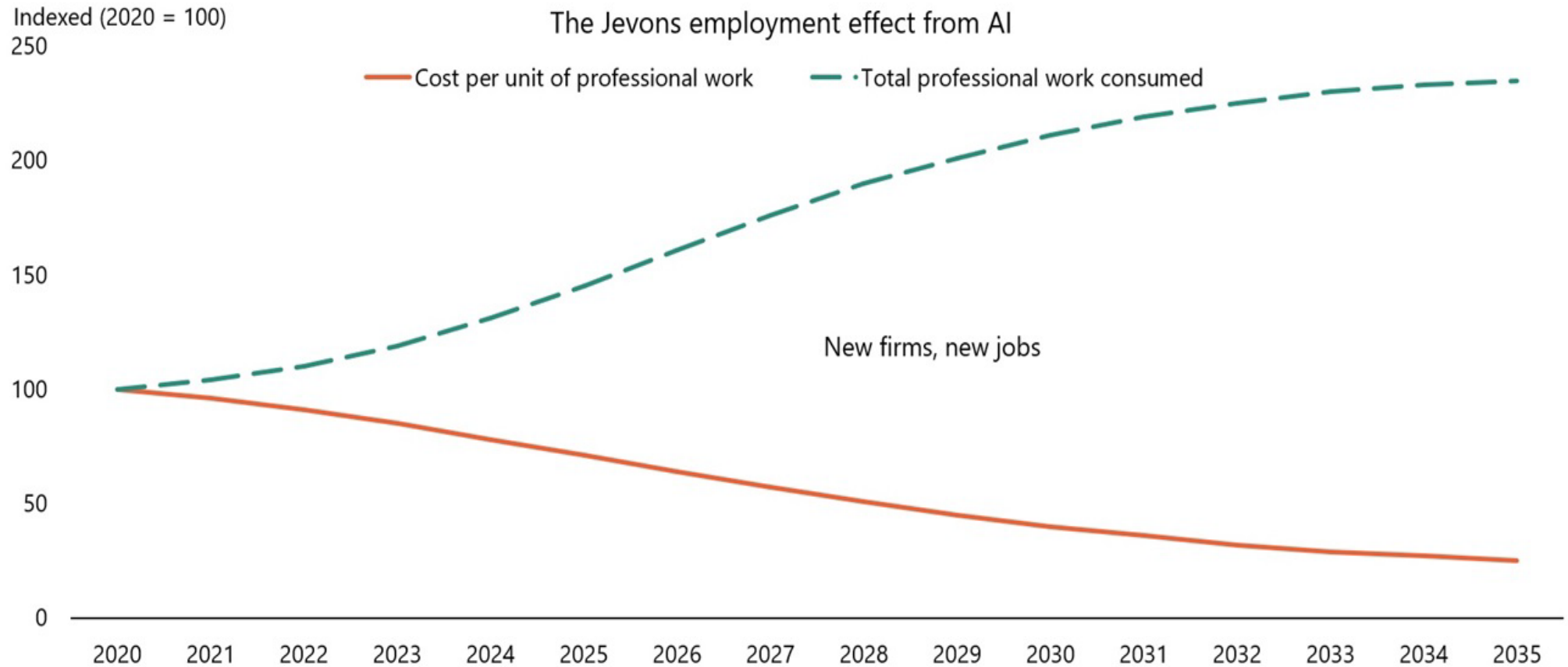

Source: Apollo



Accounting & bookkeeping services employment

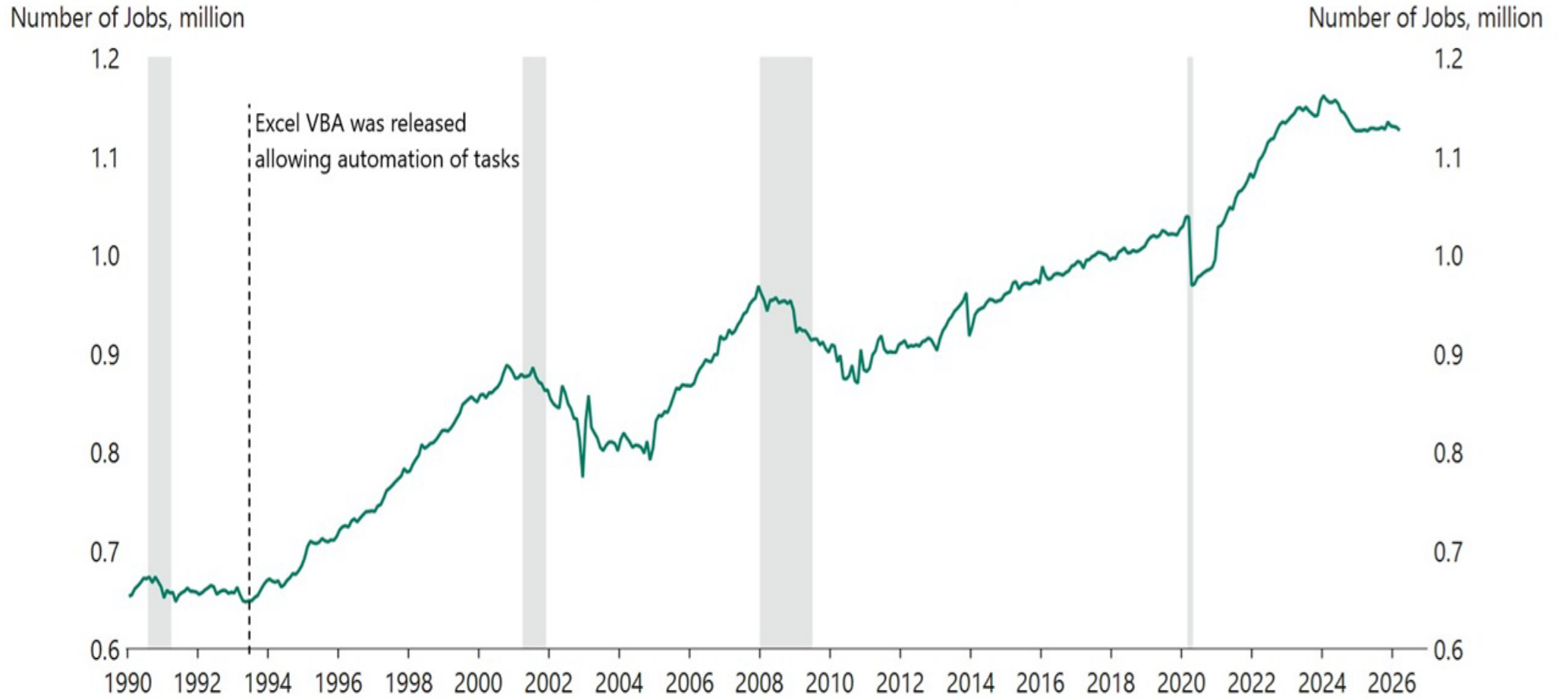

Source: Apollo

Radiology accounts for the vast majority of AI medical devices

Annual number of AI-enabled medical devices cleared by the FDA

Radiology All other devices

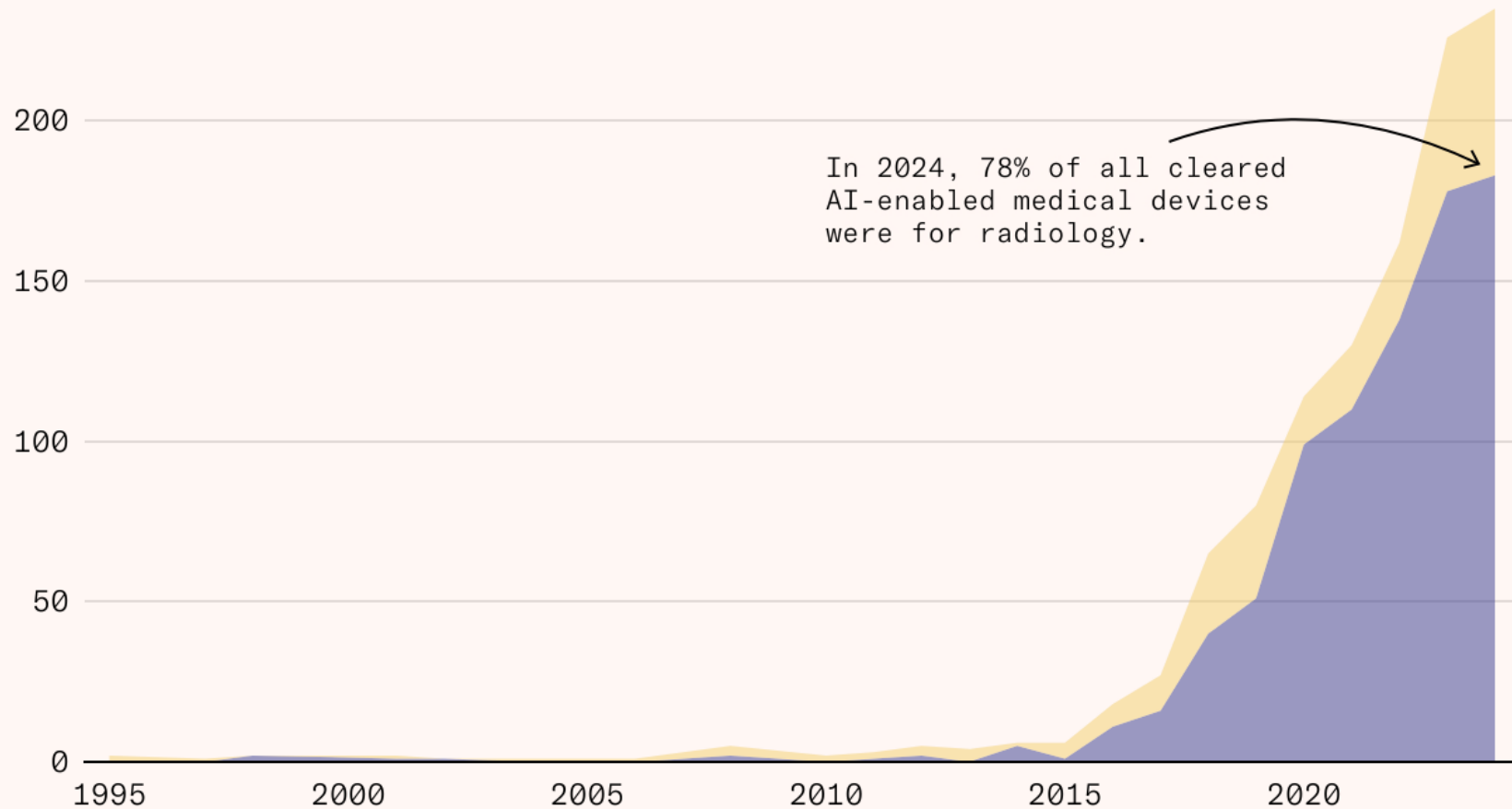

Source: Food and Drug Administration (2025)

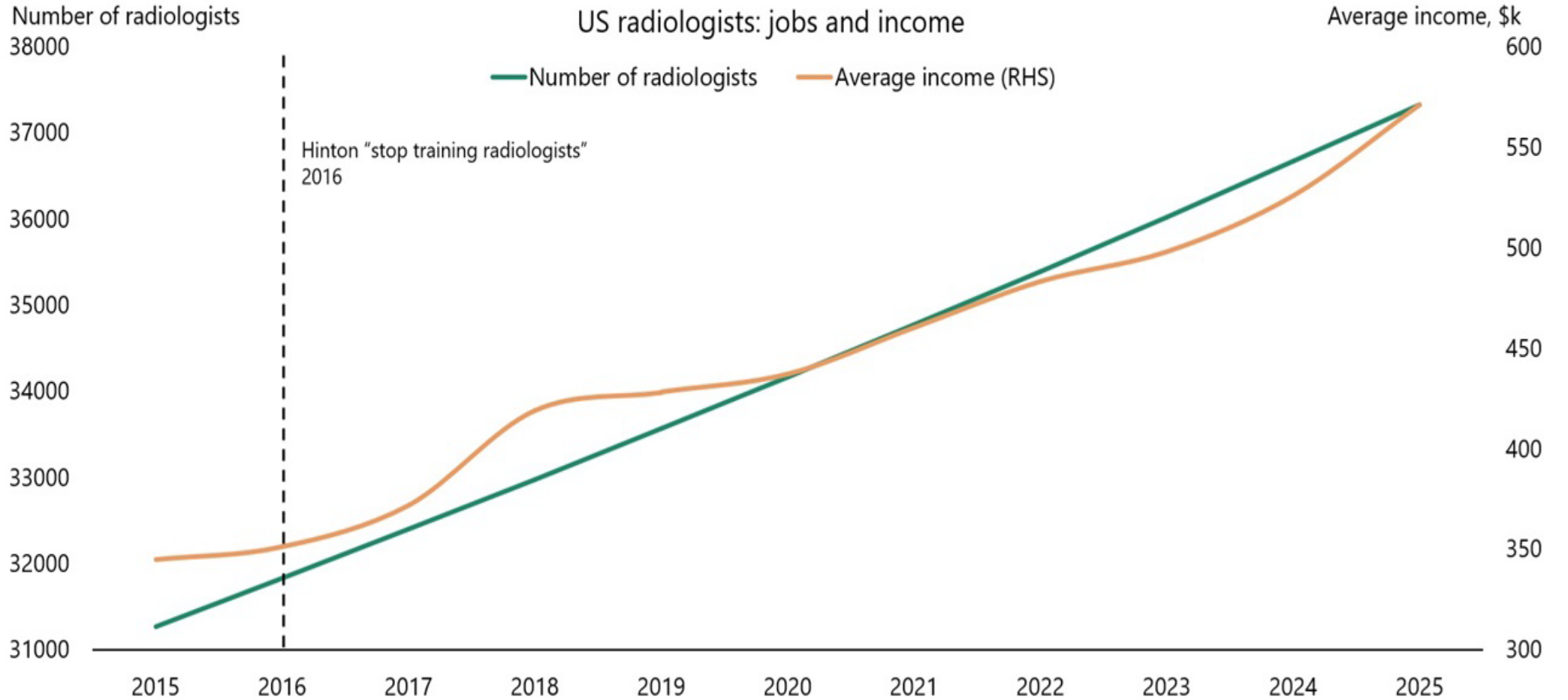

Source: Apollo

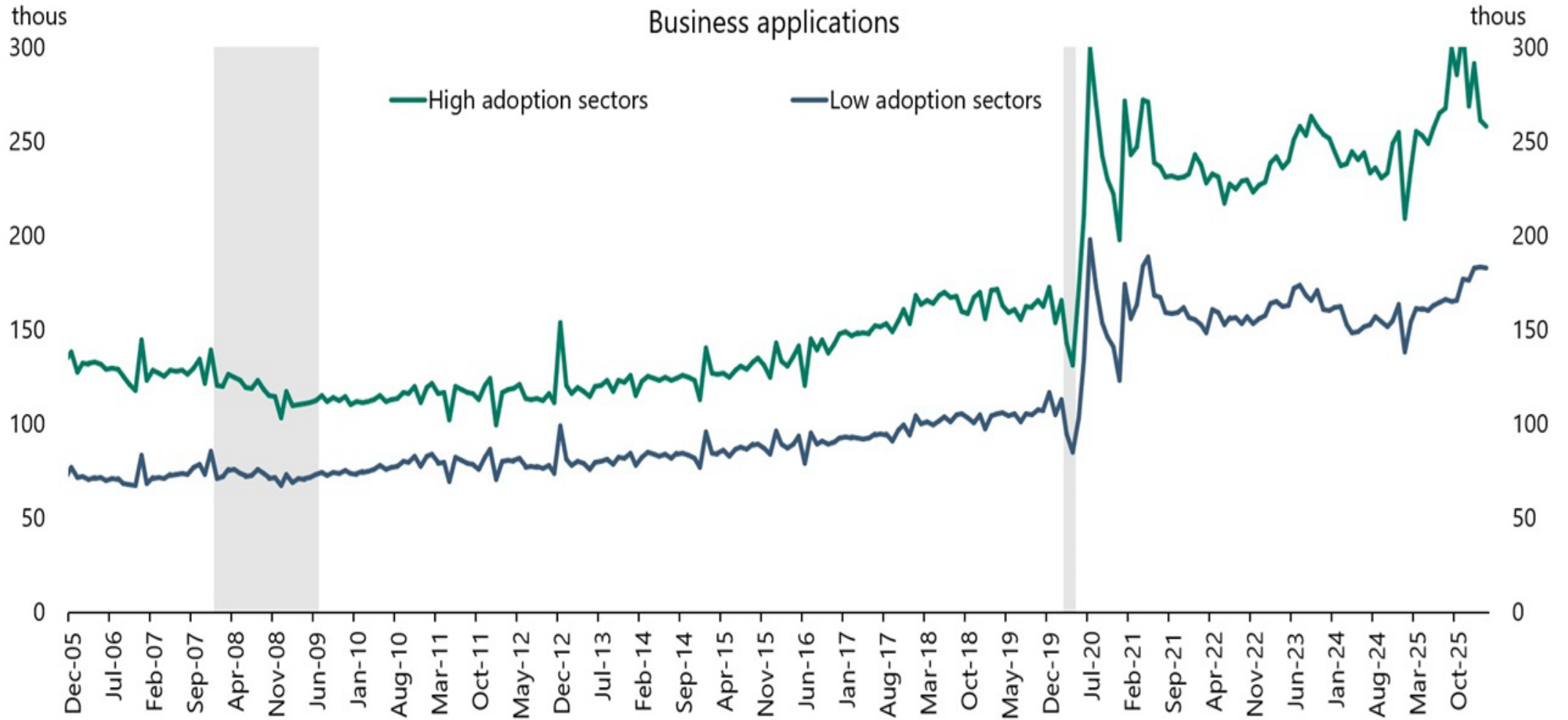

Source: Apollo

US payroll employment in the travel agency industry

Thousands

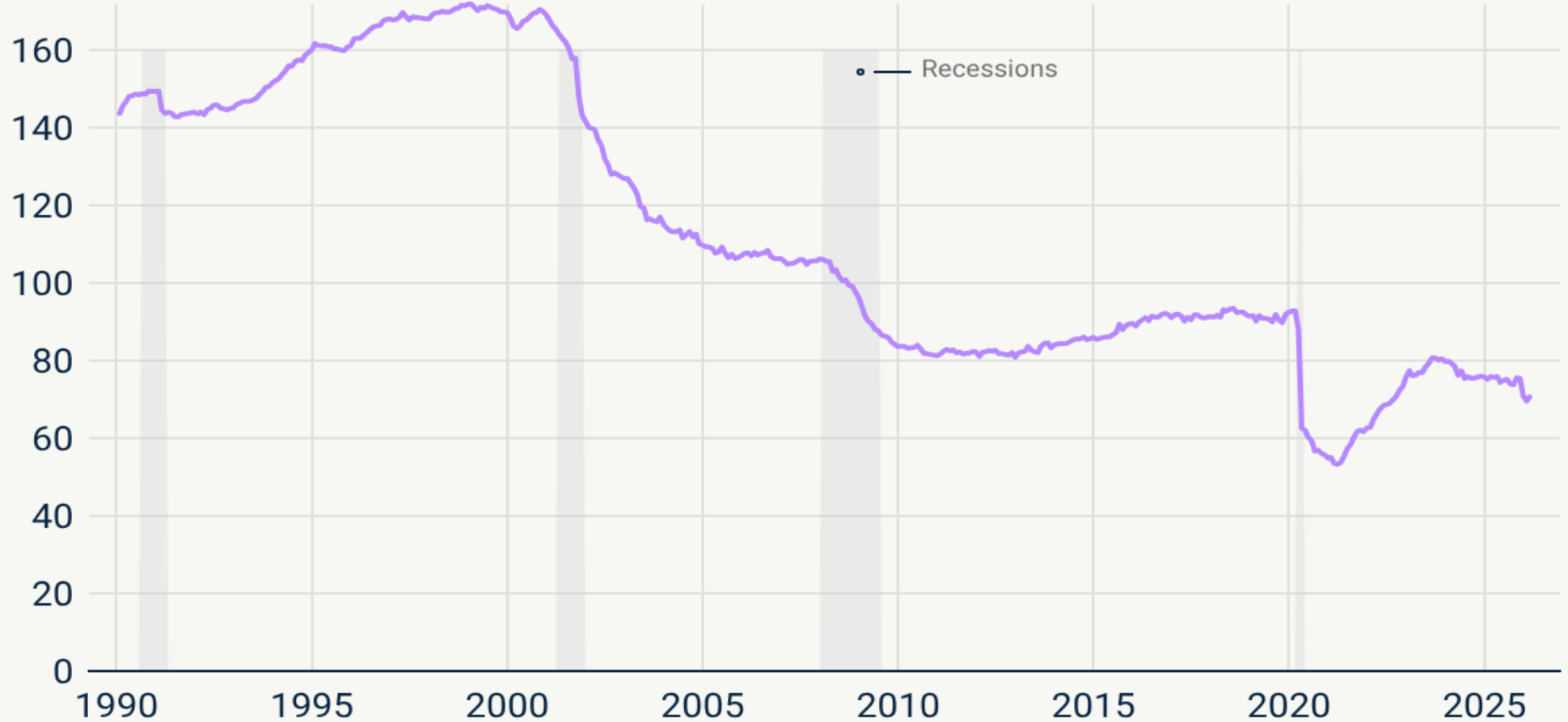

Source(s): Bureau of Labor Statistics, Stripe analysis

Ratio of US travel agency-to-overall average weekly earnings

Production and nonsupervisory workers

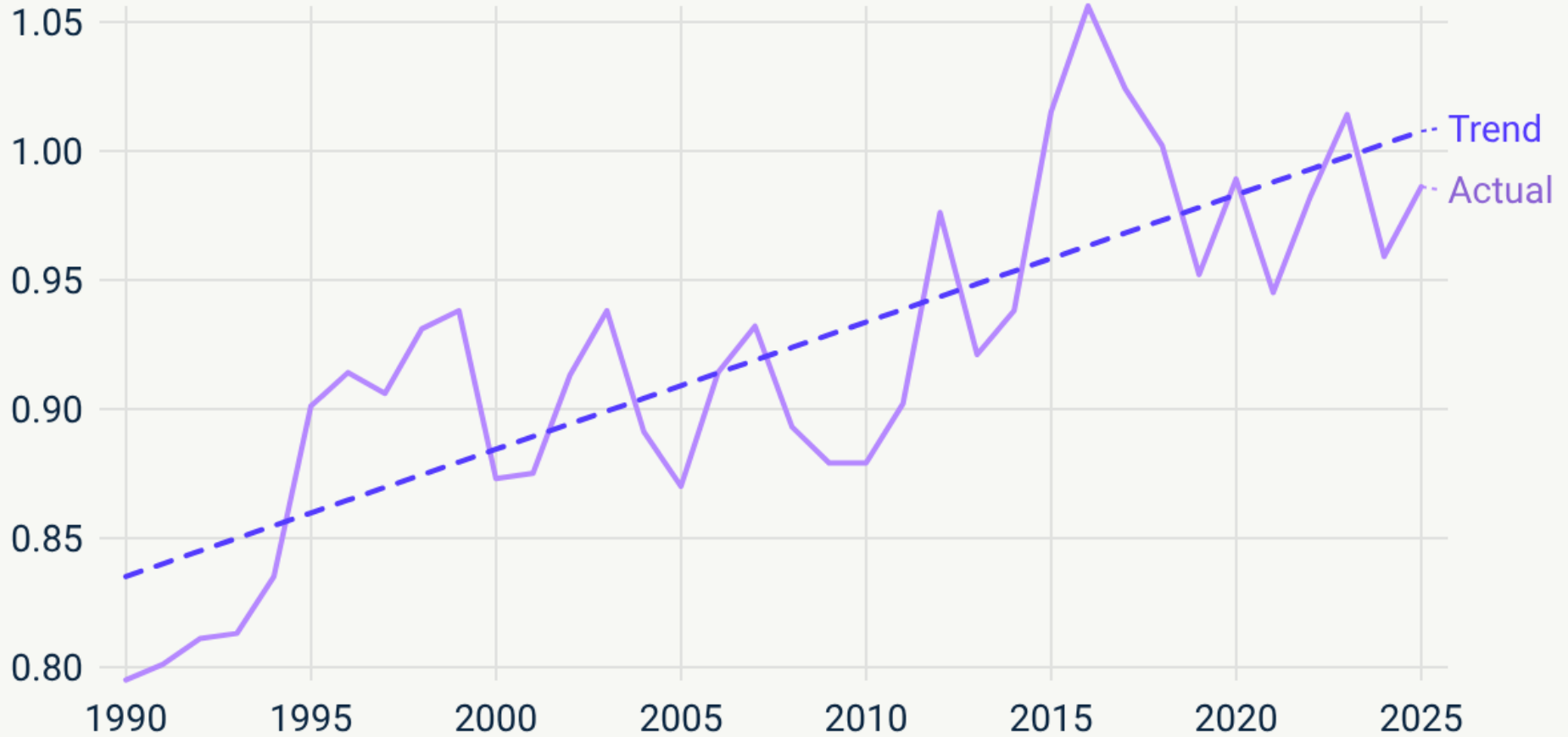

Travel Agency industry

Source(s): Bureau of Labor Statistics, Stripe analysis



FRED  ● Real Personal Consumption Expenditures

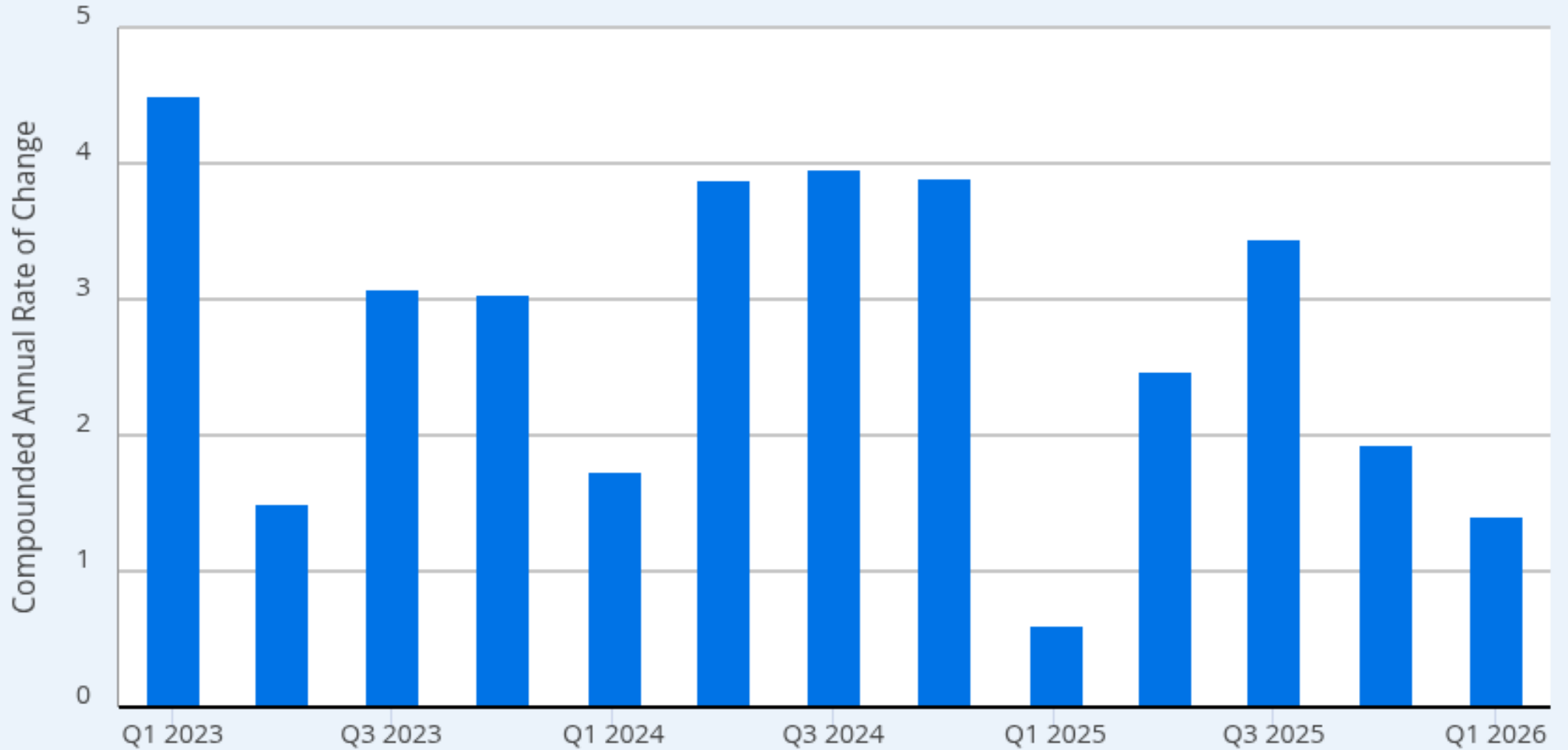

Source: U.S. Bureau of Economic Analysis via FRED®

Shaded areas indicate U.S. recessions.

myf.red/g/1WKqi

Wage growth in April was 3.6% (for past year). Inflation in April was 3.8%.

— CPI Inflation — Wage Growth

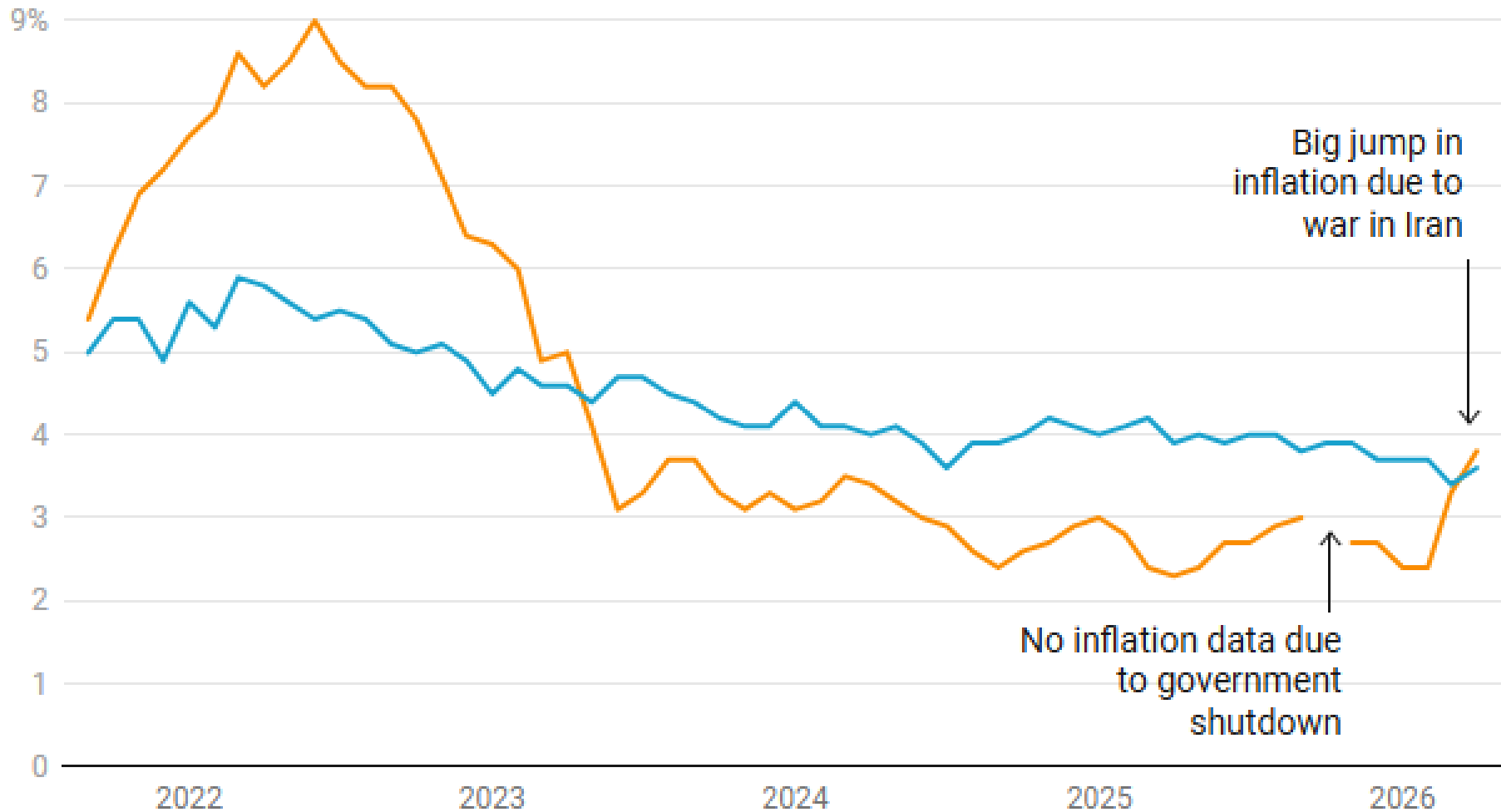

Data is seasonally adjusted. Wage growth refers to average hourly earnings.

[Get the data](#) • Created with [Datawrapper](#)



University of Michigan consumer sentiment index

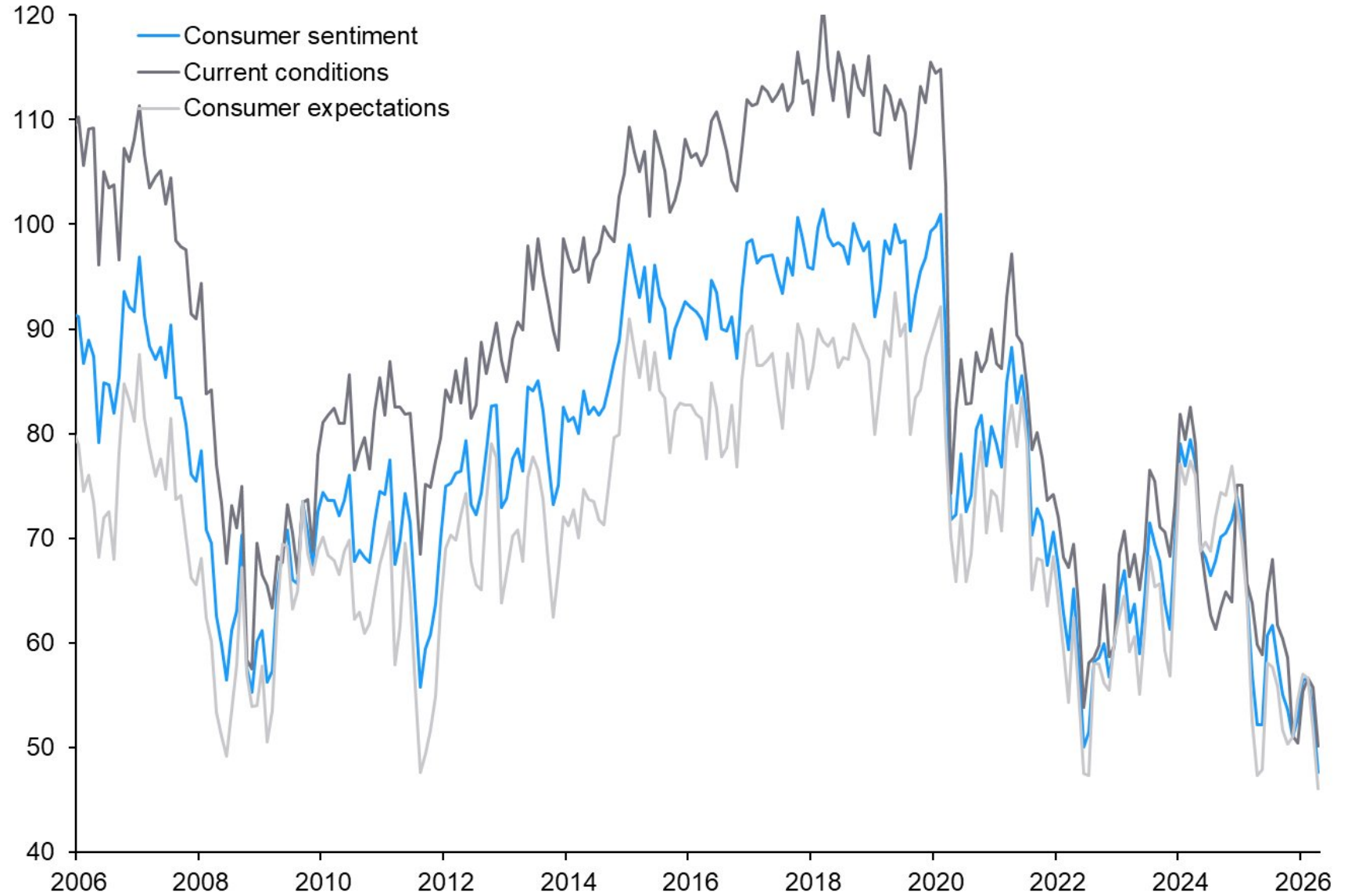

Source: University of Michigan; EY-Parthenon



FRED



— Personal consumption expenditures: Services (chain-type price index)
- - Personal consumption expenditures: Goods (chain-type price index)

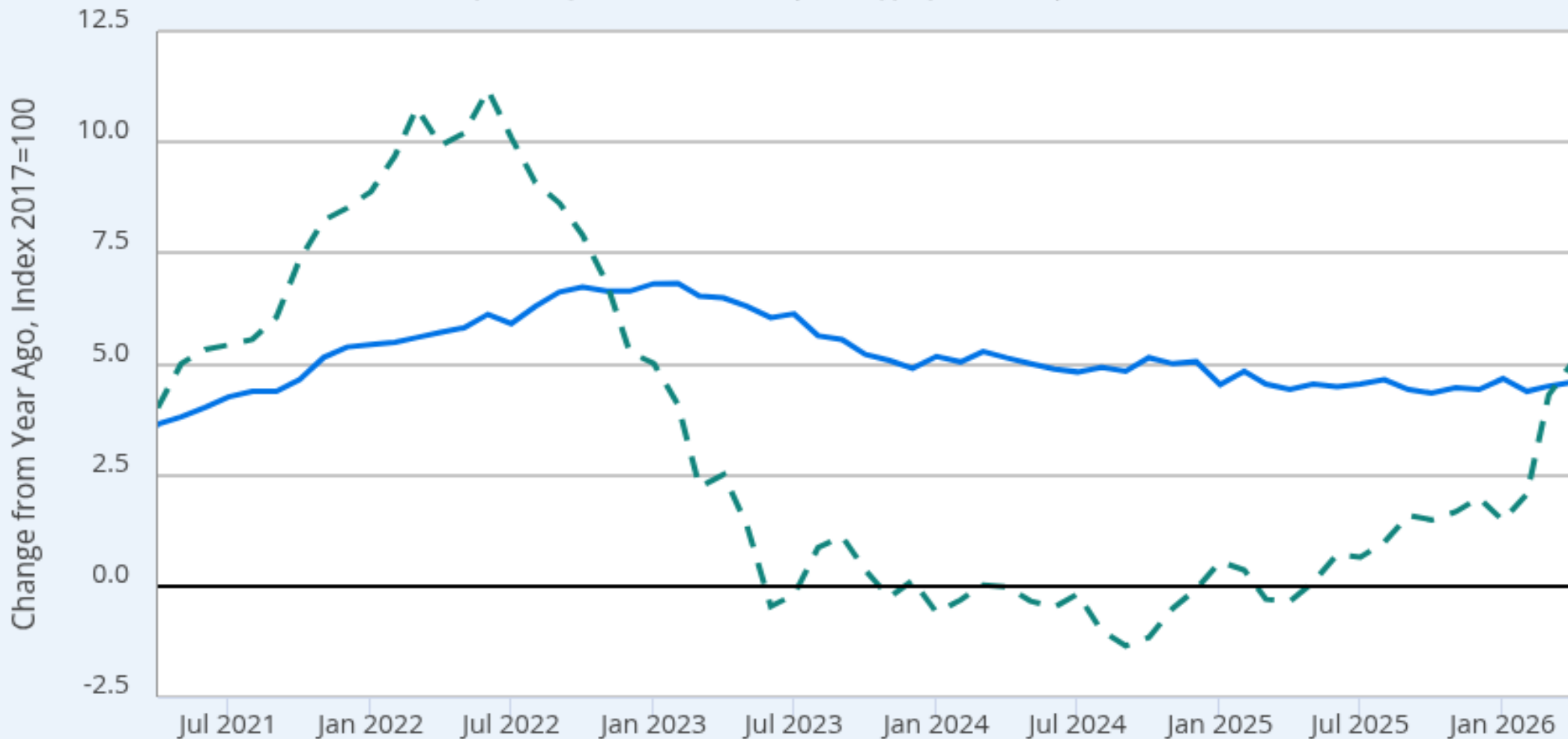

Source: U.S. Bureau of Economic Analysis via FRED®

Shaded areas indicate U.S. recessions.

myf.red/g/1WKXN

Figure 6. Assessment of own financial well-being, local economy, and national economy (by year)

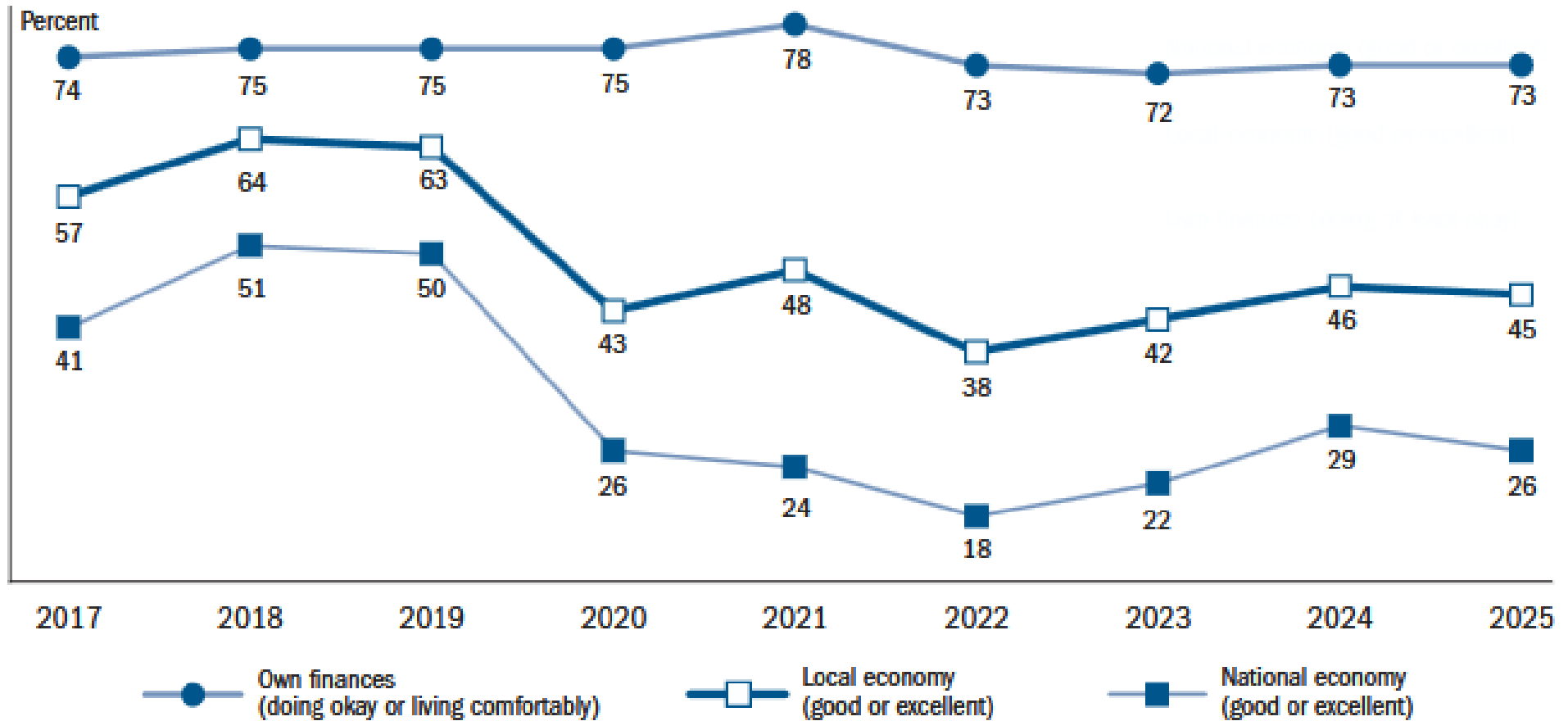

Note: Among all adults. The estimates for each of the series on the figure represent the two most favorable response choices. The four response options for own finances were “living comfortably,” “doing okay,” “just getting by,” and “finding it difficult to get by.” The response options for the local economy and the national economy were “good,” “excellent,” “fair,” and “poor.”

Year-over-year percent change in consumer price index (CPI)

January 2020 - April 2026

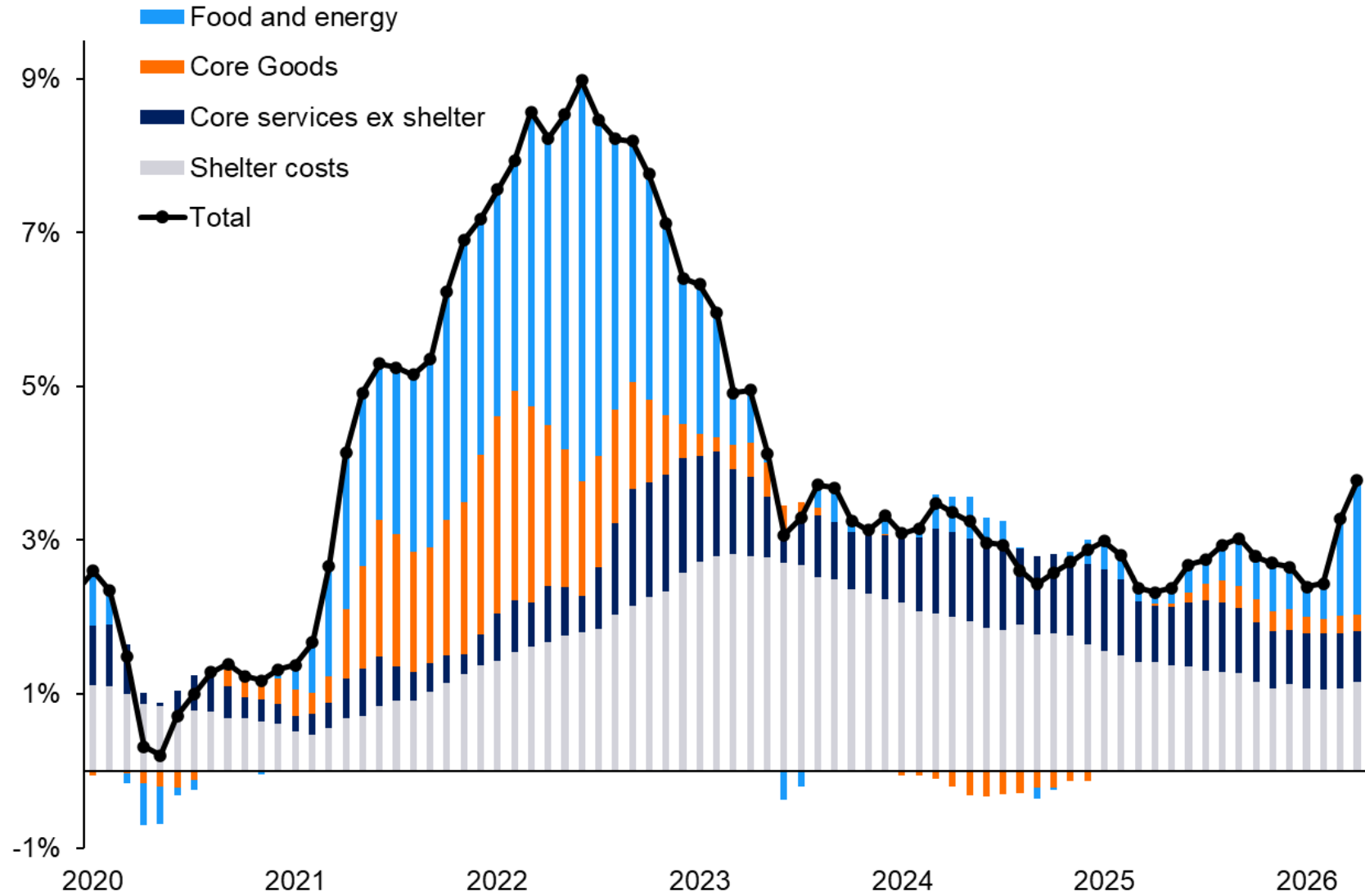

Source: BLS; EY-Parthenon

World oil transit (million barrels per day)

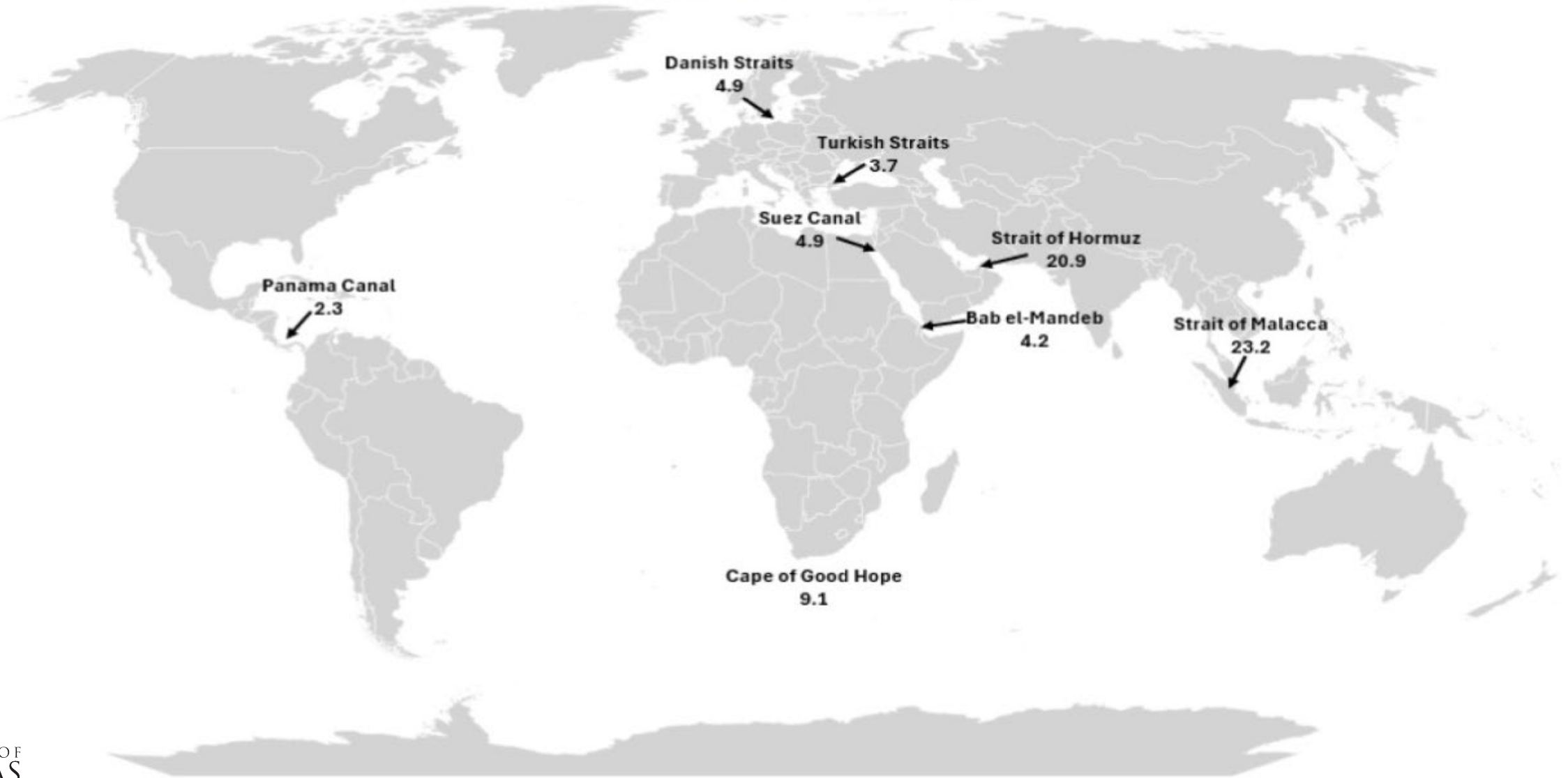

Year-over-year percent change in personal consumption expenditure prices

January 2019 - April 2026

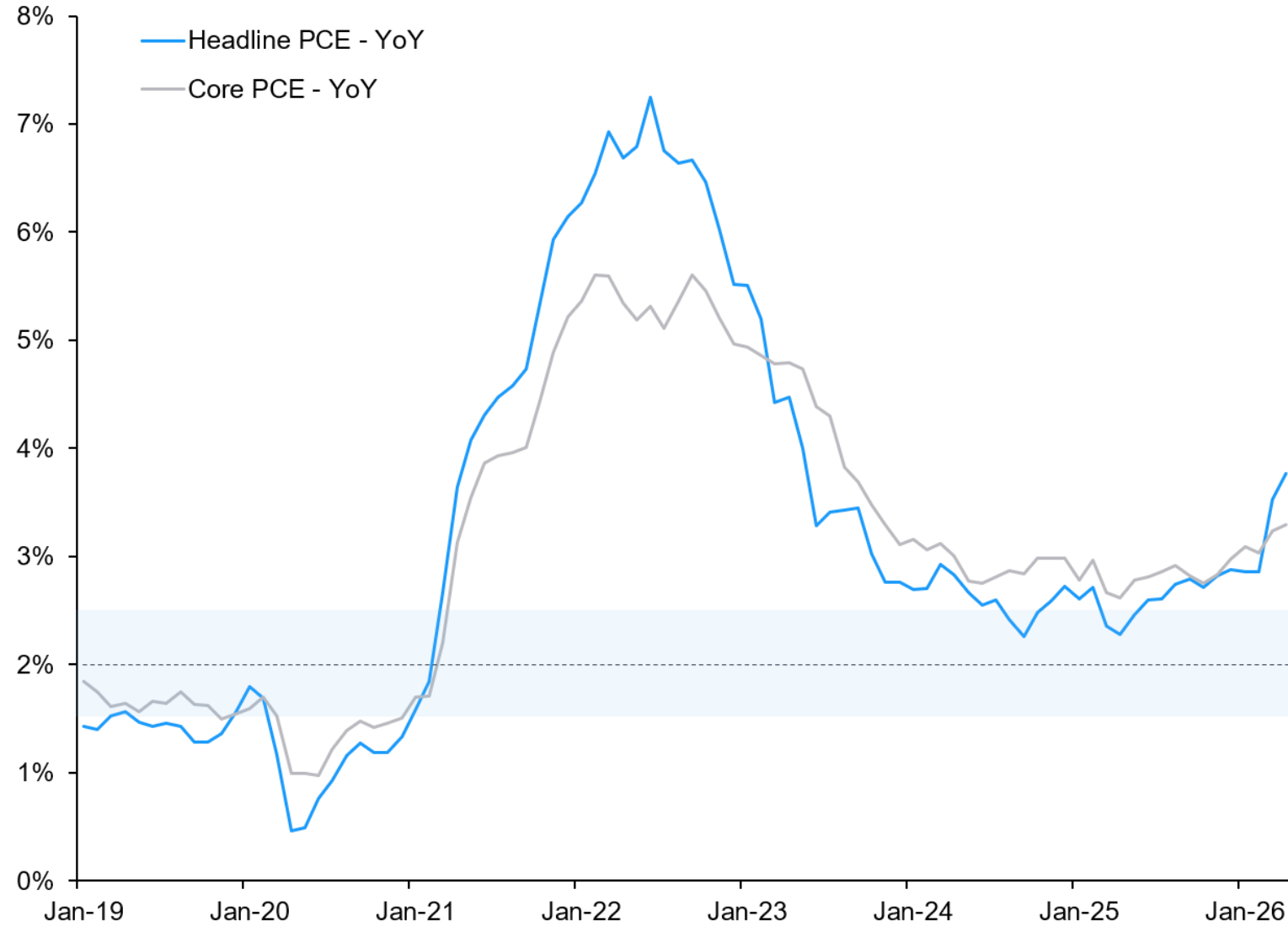

Source: BEA; EY-Parthenon



FRED

- Trimmed Mean PCE Inflation Rate
- - Personal Consumption Expenditures Excluding Food and Energy (Chain-Type Price Index)
- Median Consumer Price Index
- - Personal Consumption Expenditures: Chain-type Price Index

Percent Change from Year Ago, Change from Year Ago, Index 2017=100, Percent Change at Annual Rate

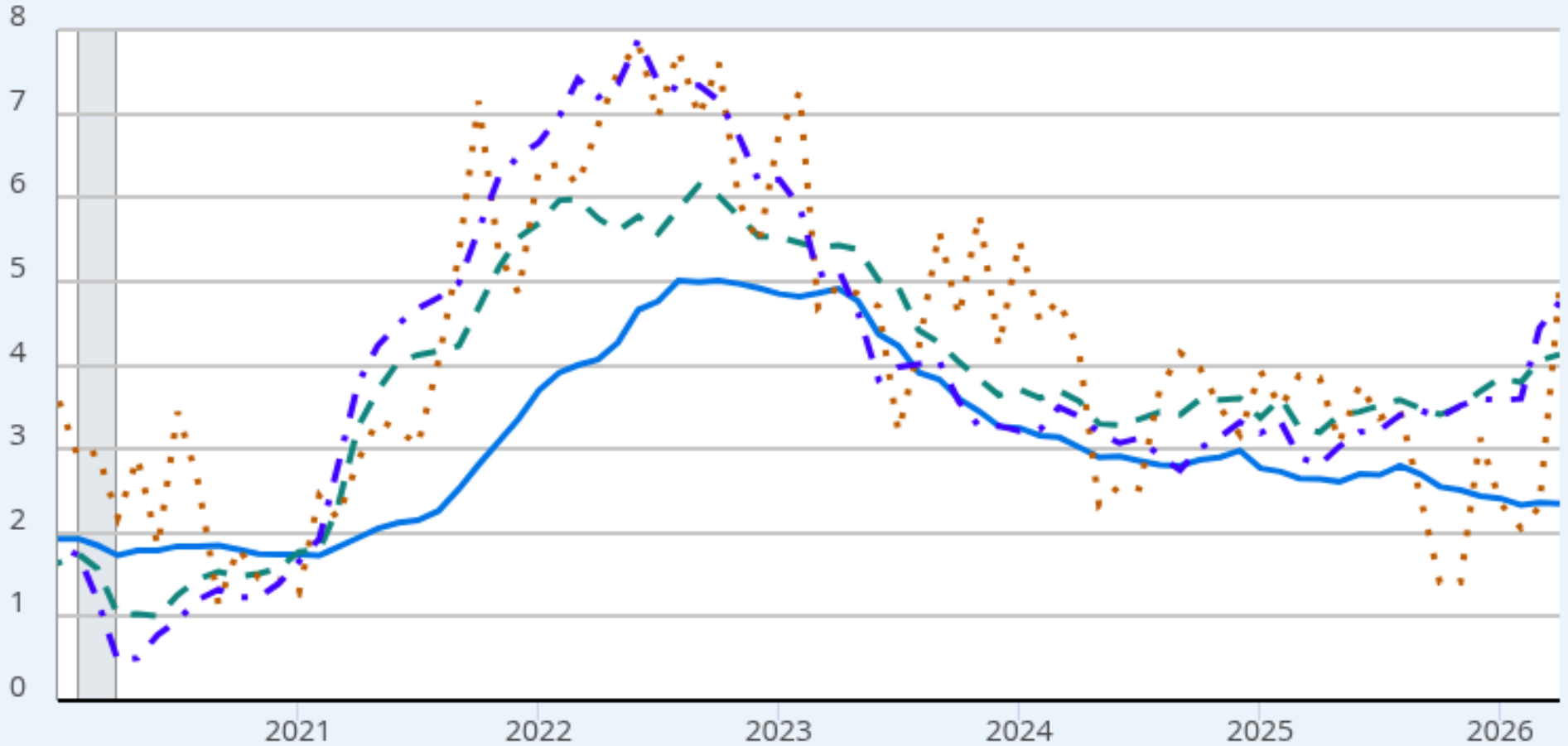

Sources: Federal Reserve Bank of Cleveland; Federal Reserve Bank of Dallas; U.S. Bureau of Economic Analysis via ...
Shaded areas indicate U.S. recessions. myf.red/g/1WKSb

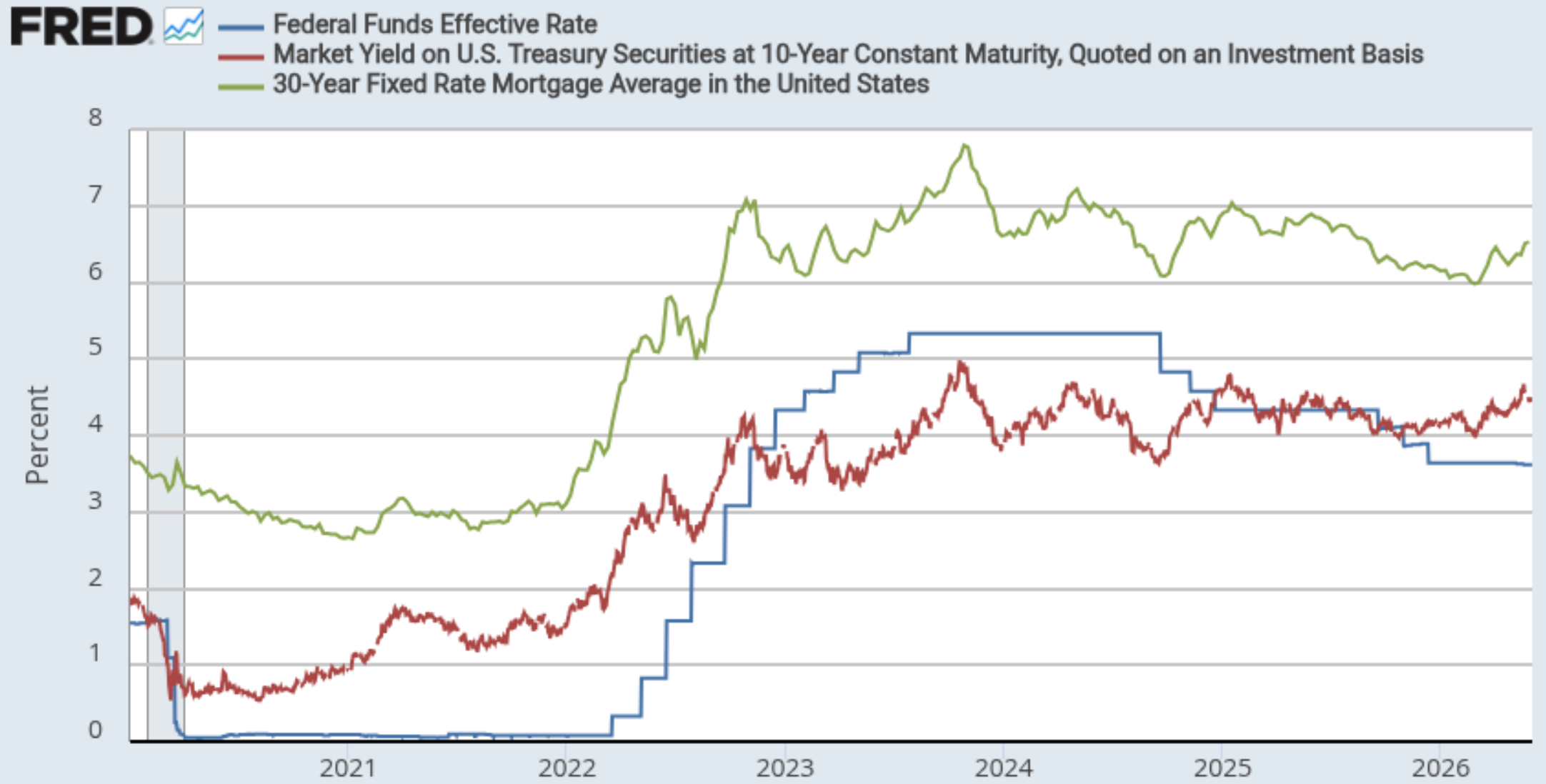

Sources: Board of Governors of the Federal Reserve System (US); Freddie Mac via FRED®

Shaded areas indicate U.S. recessions.

myf.red/g/1WKSf



FRED

● Real Private Residential Fixed Investment

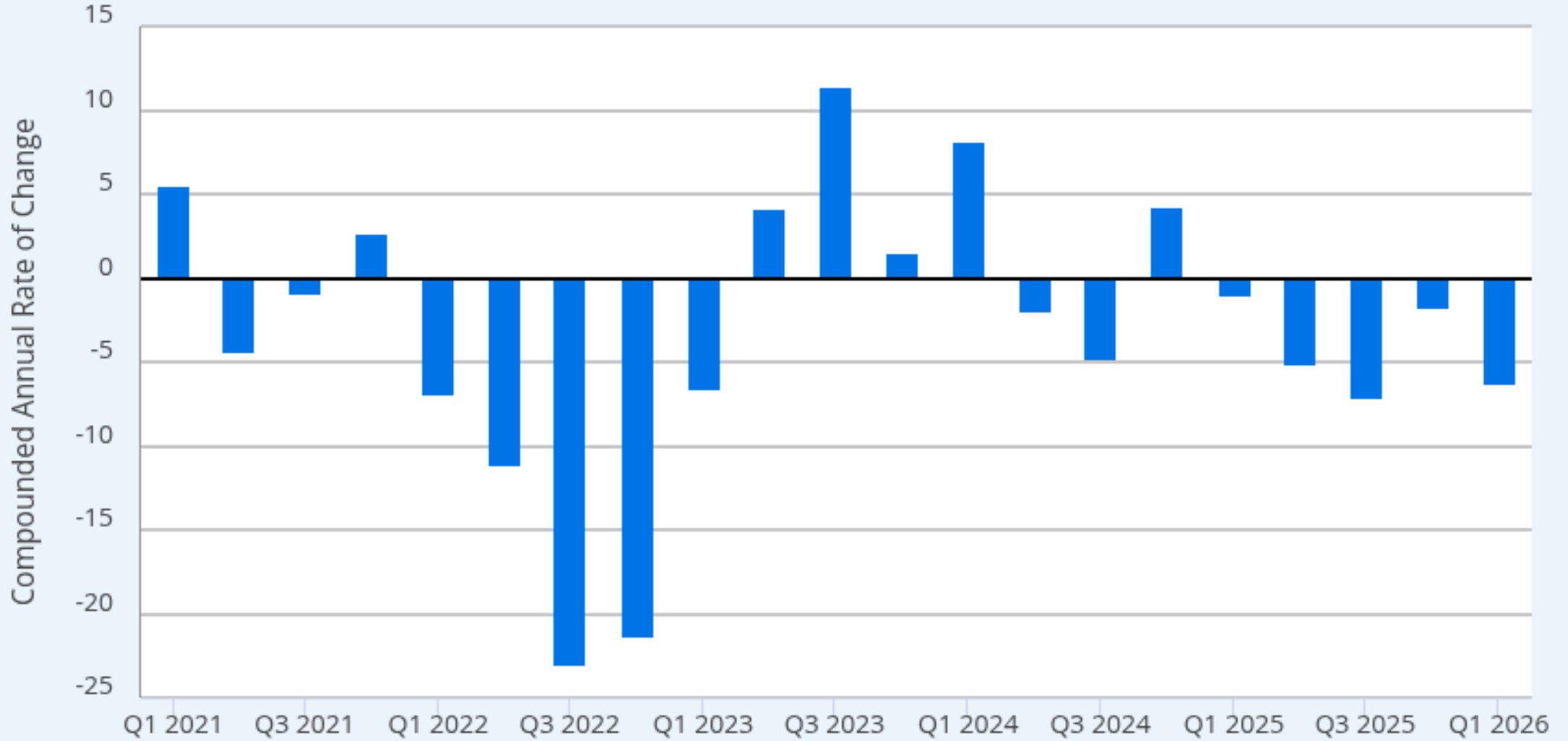

Source: U.S. Bureau of Economic Analysis via FRED®

Shaded areas indicate U.S. recessions.

myf.red/g/1WKSj

Residential renovations as share of private construction spending



Sources: US Census Bureau, Bloomberg, Macrobond, Apollo Chief Economist



Benton and Washington County Number of House Starts in Active Subdivisions

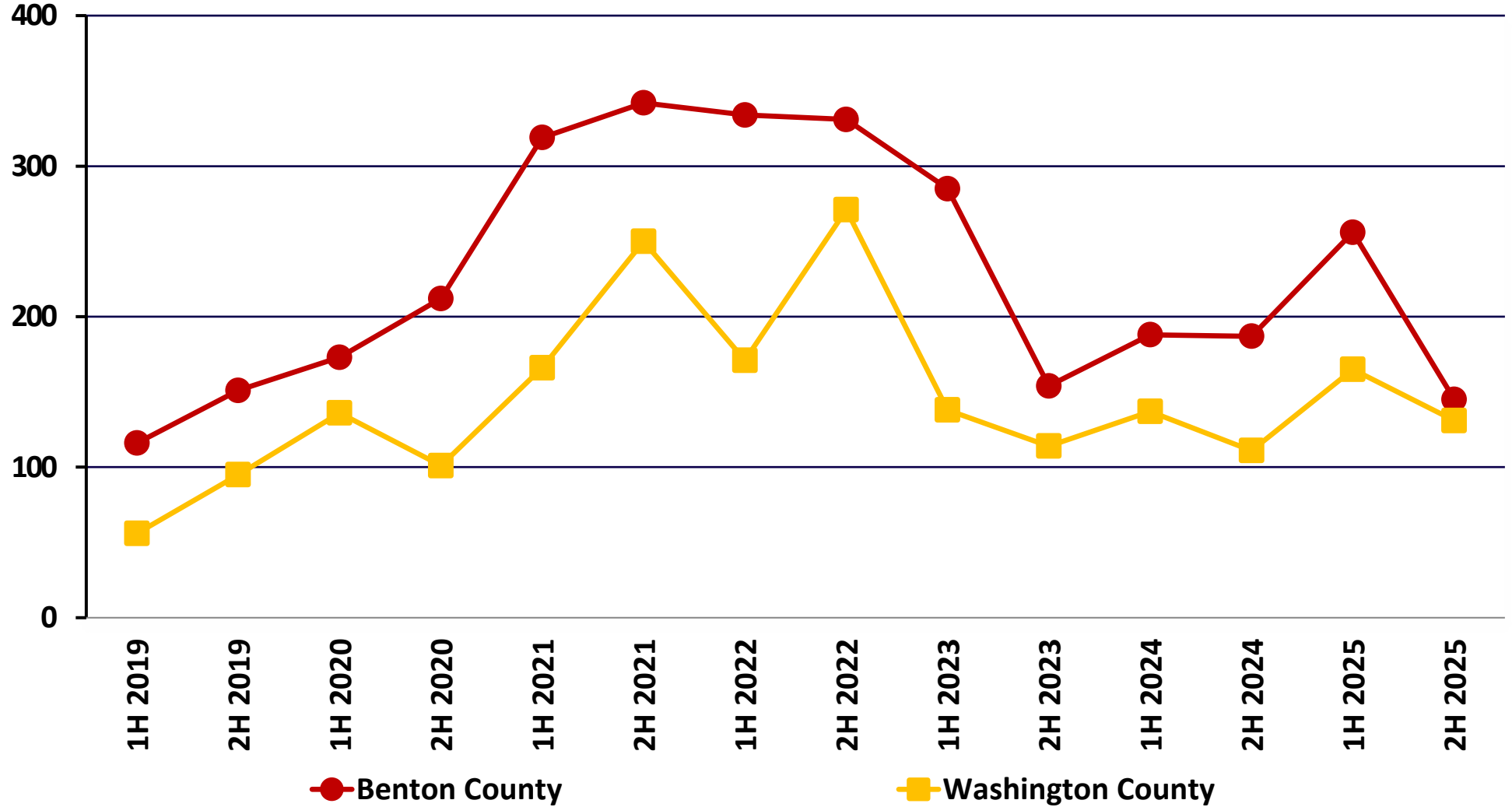

Benton, Madison and Washington County Number of Houses Sold

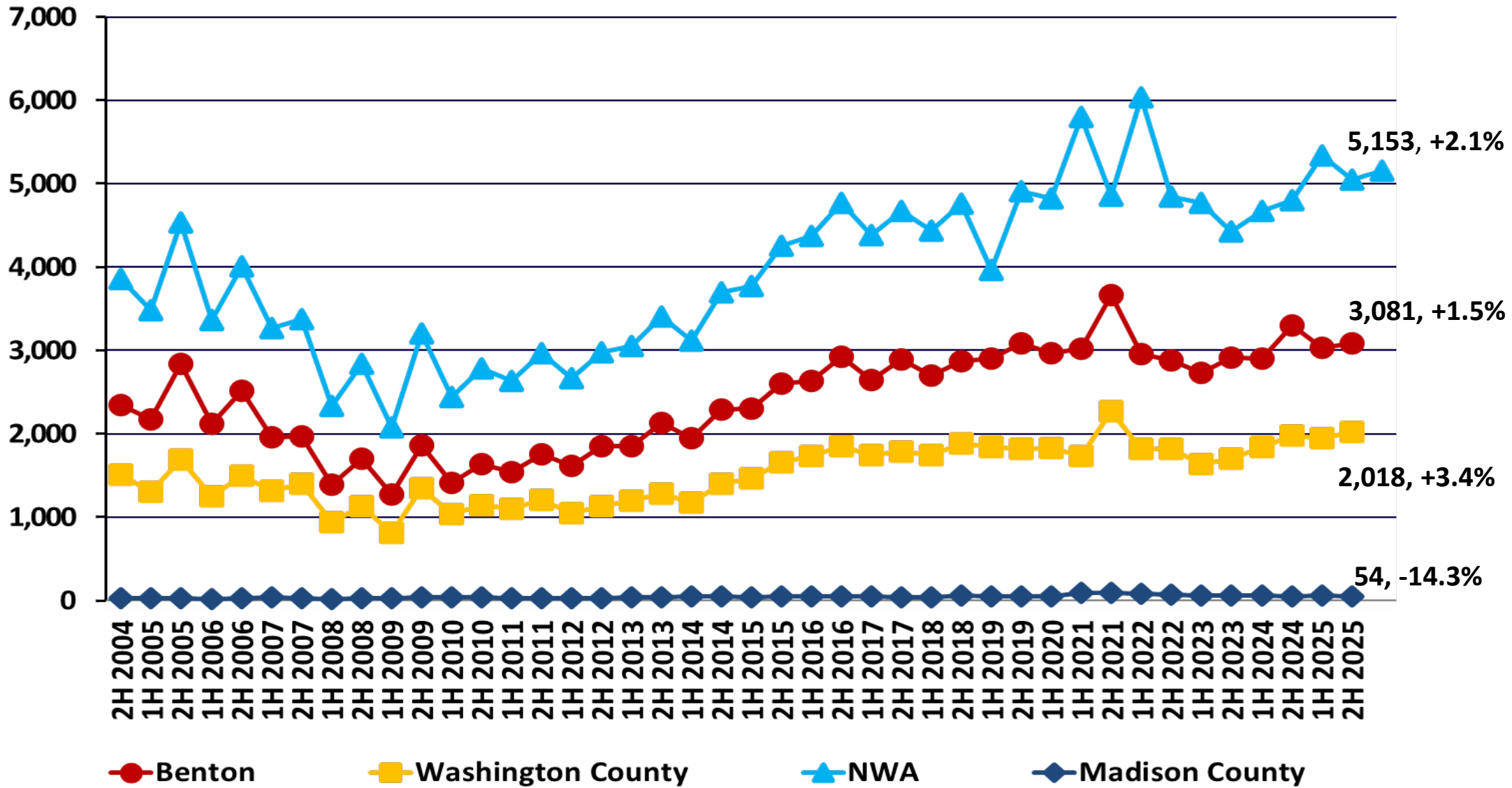

NWA Number of Houses Sold

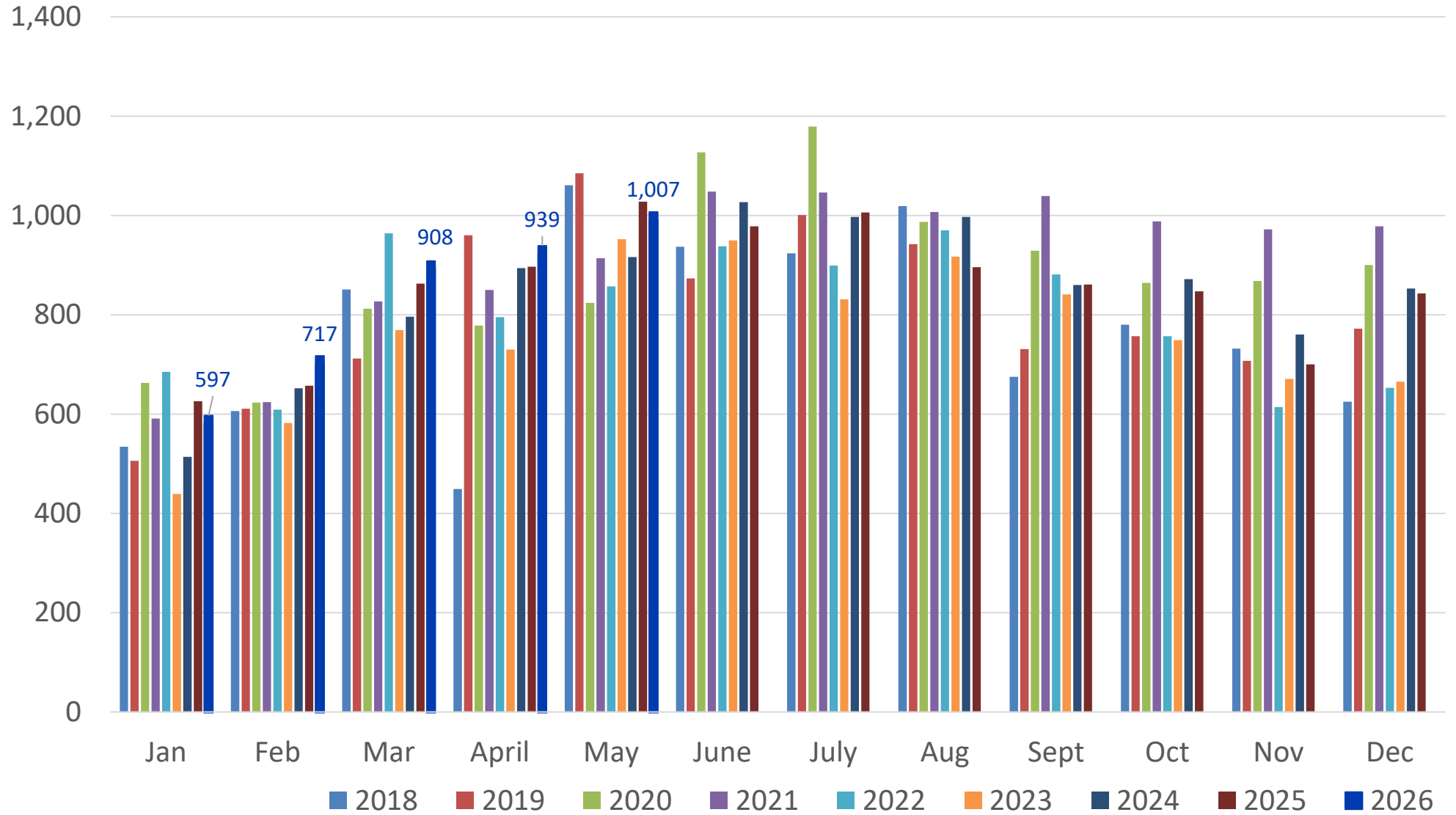

Source: Skyline Report, MLS Database

Benton, Madison and Washington County Average Price of Houses Sold

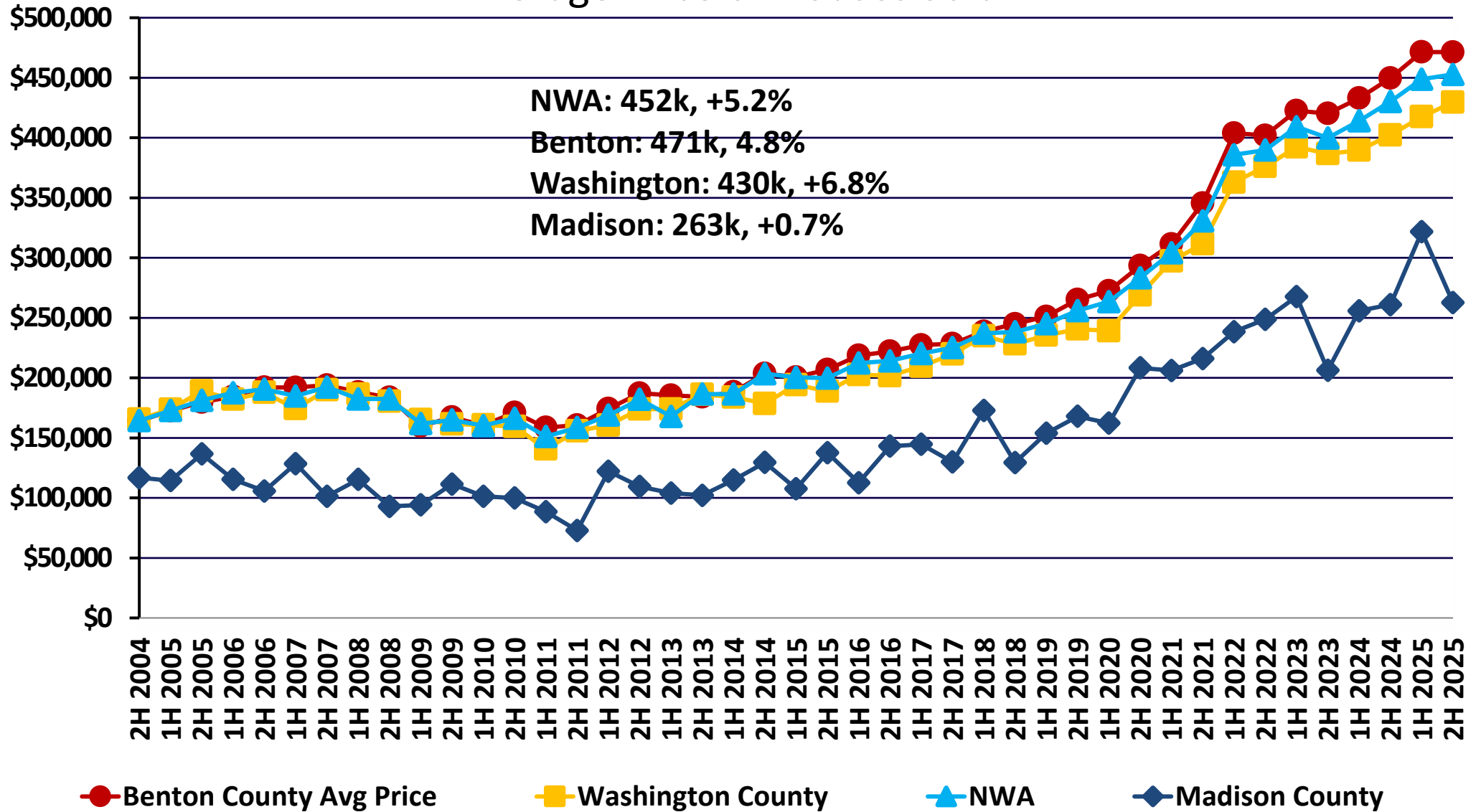

Average Price of Houses Sold

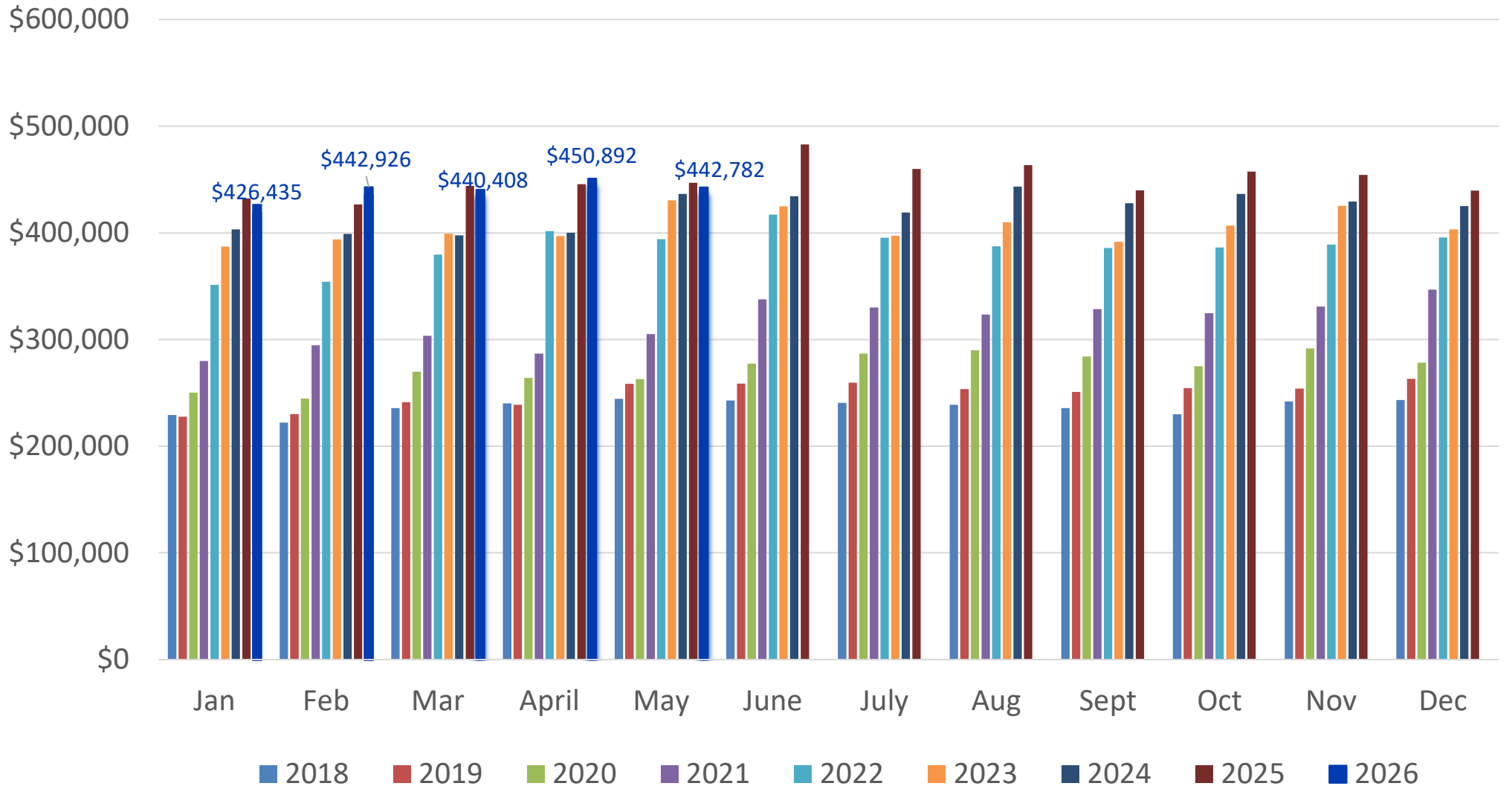

Source: Skyline Report, MLS Database



Benton County Housing Median Multiple

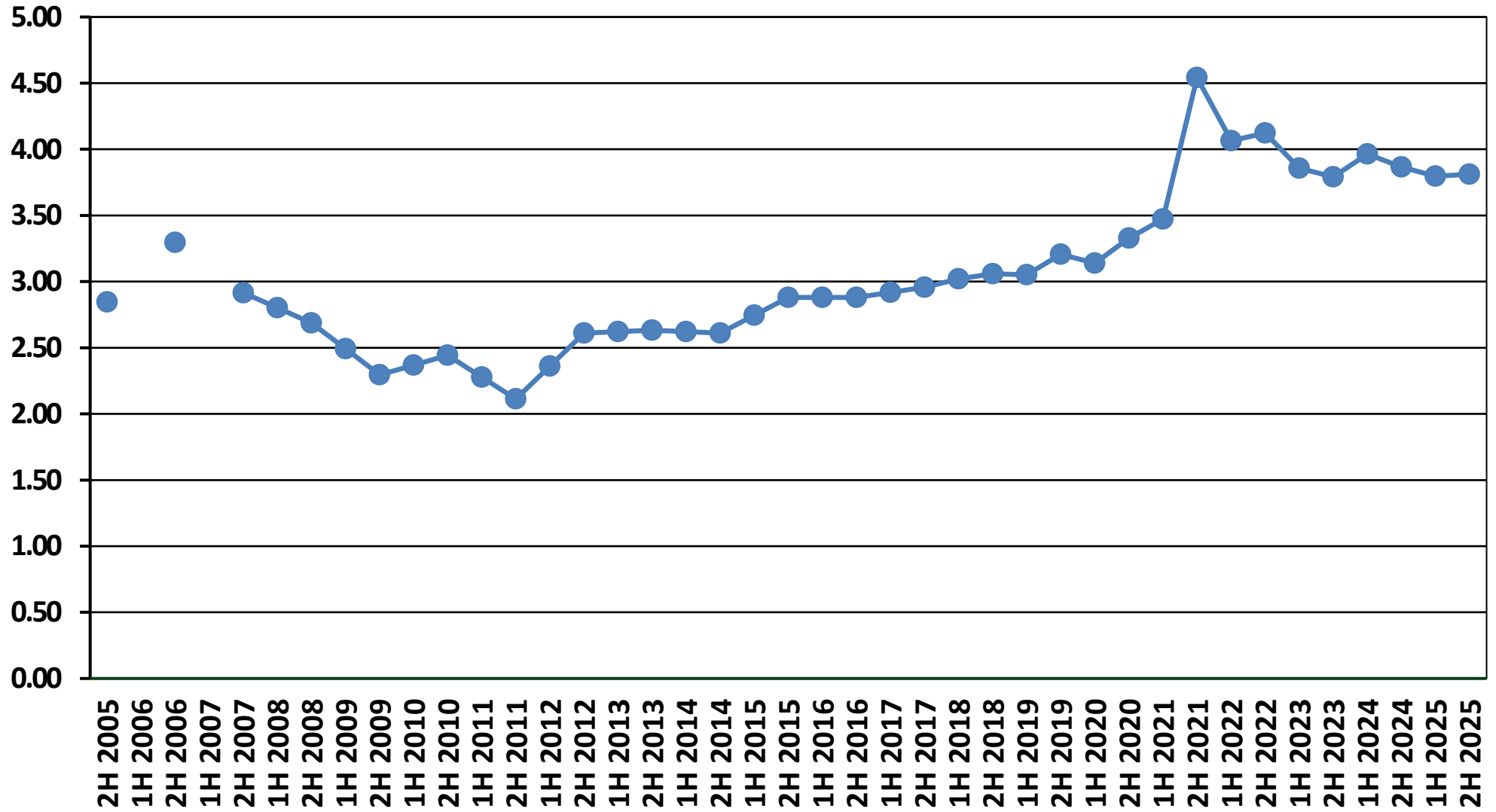



Washington County House Median Multiple

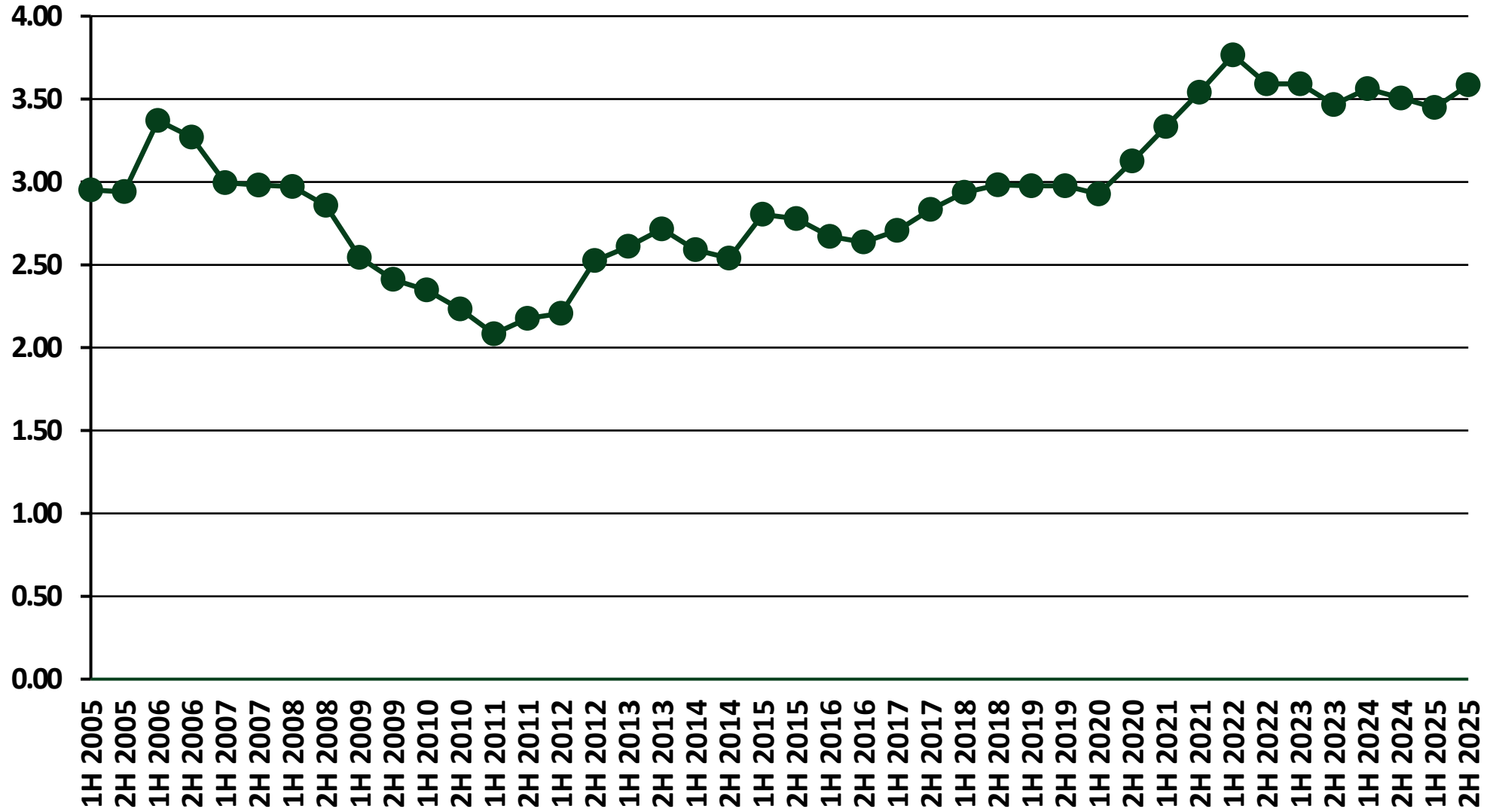



Benton County Absorption and Completed Inventory

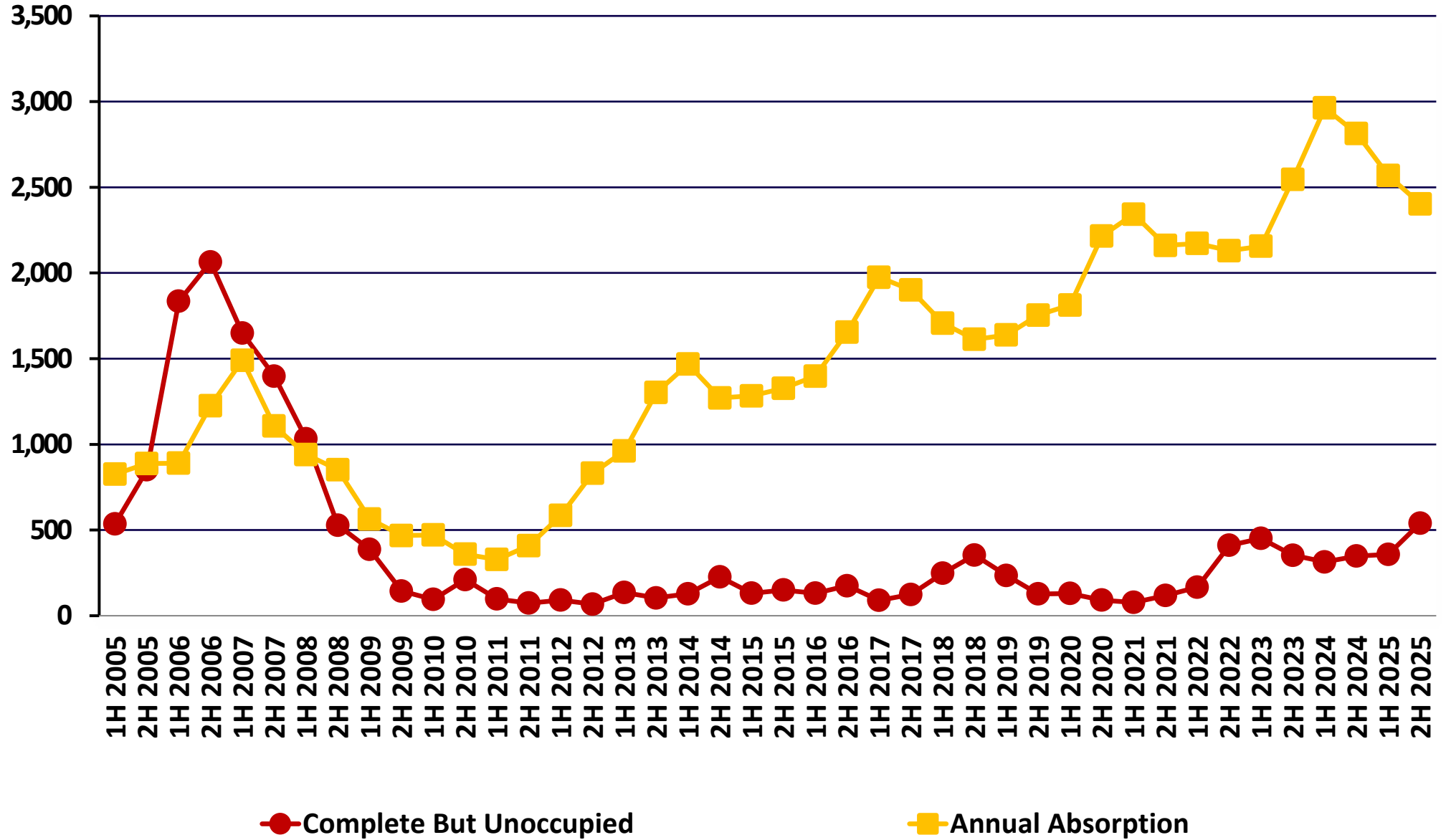

Selected Cities Multifamily Average Vacancy Rates by City

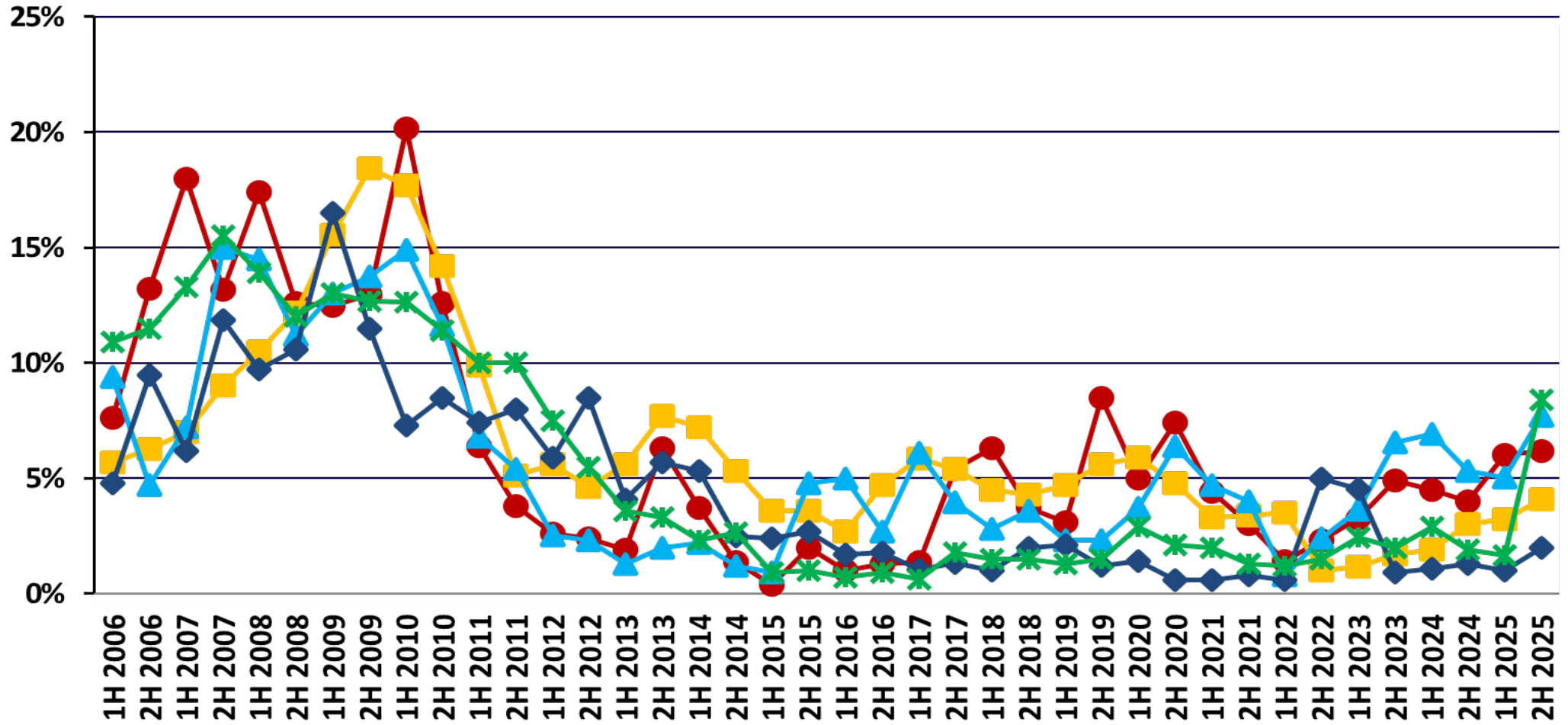

● Bentonville
 ■ Fayetteville
 ▲ Rogers
 ◆ Siloam Springs
 ✱ Springdale

● 6.2%
 ■ 4.1%
 ▲ 7.7%
 ◆ 2.0%
 ✱ 8.4%



NWA Vacancy Rates Comparison

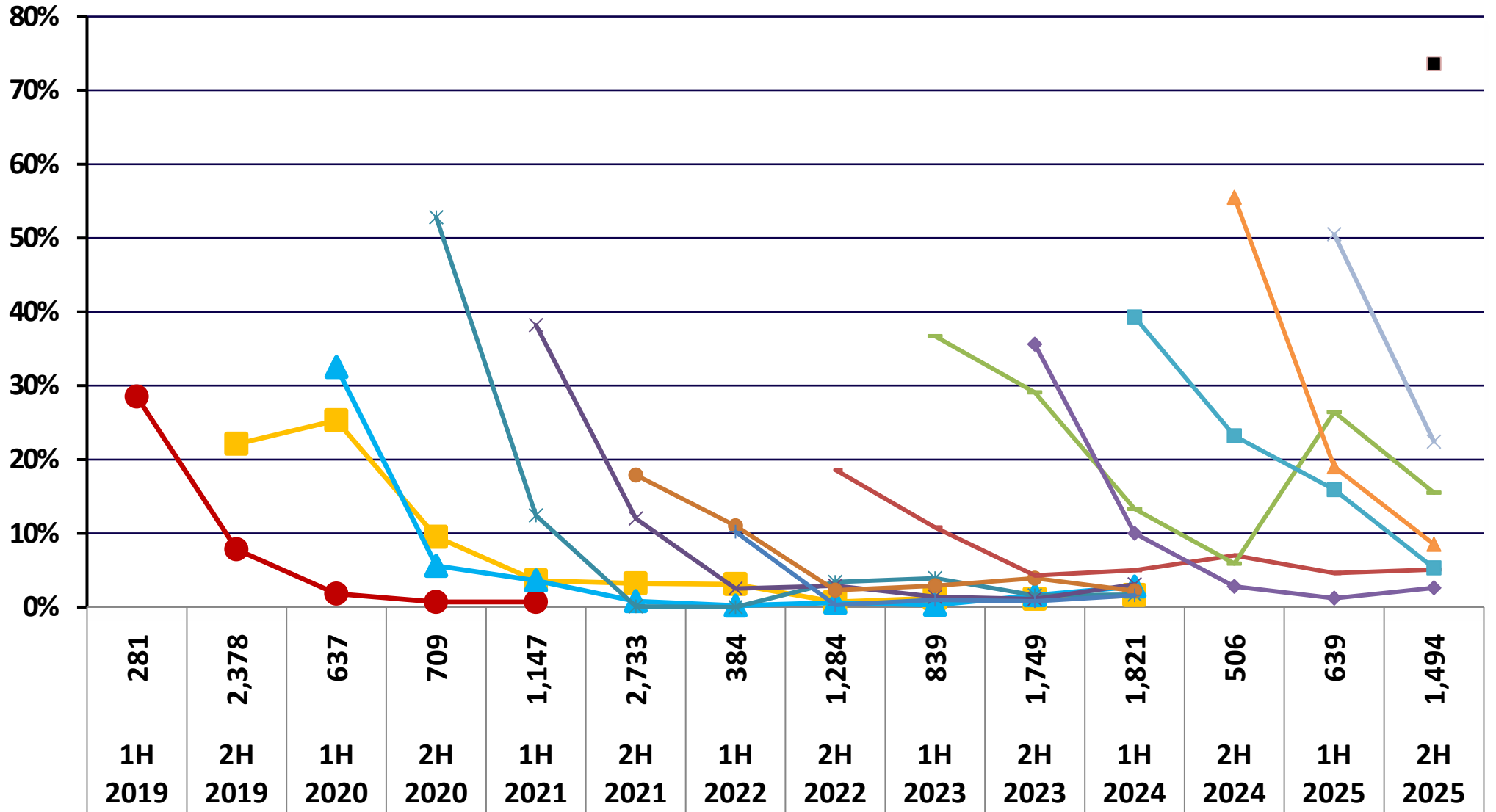



Northwest Arkansas Price per Unit

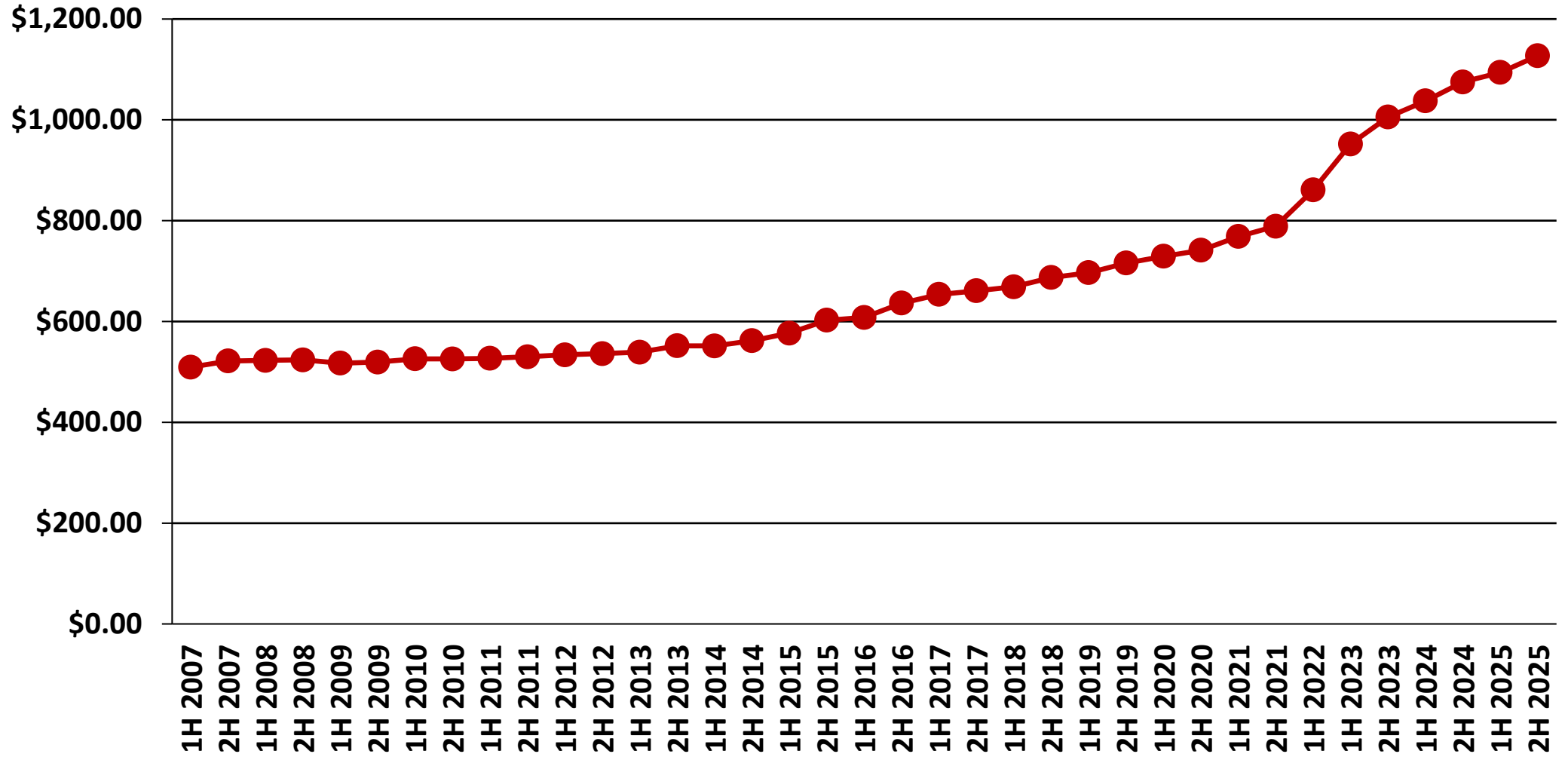

Northwest Arkansas Population Growth

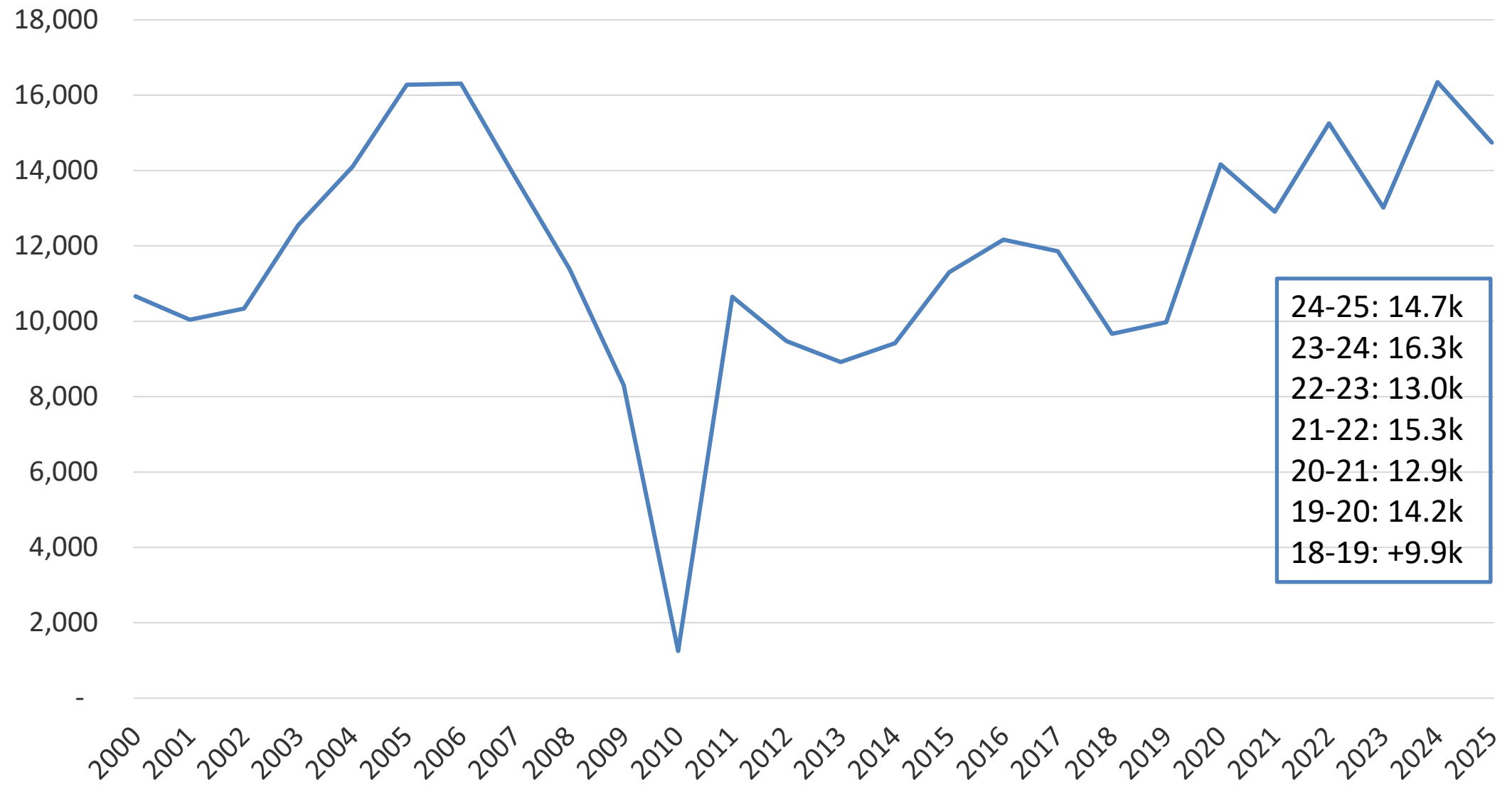

Source: U.S. Census Bureau

Americans who want kids want more bedrooms even if they're smaller

Difference in ranked value between extra room vs. no extra room at fixed square footage

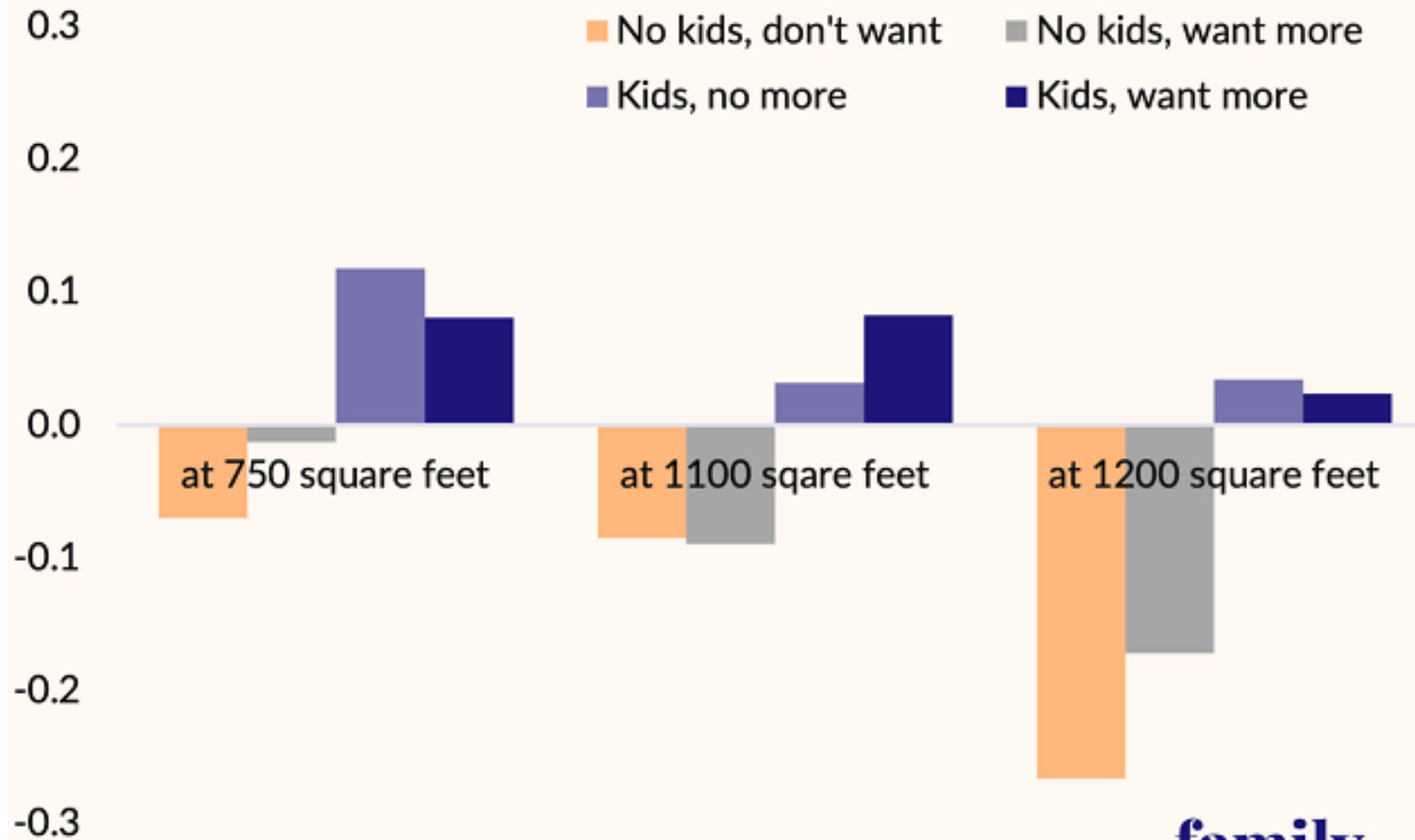

Source: IFS Multifamily Housing Survey, May 2025



Americans want apartments with more bedrooms

Average marginal component effects from a conjoint model

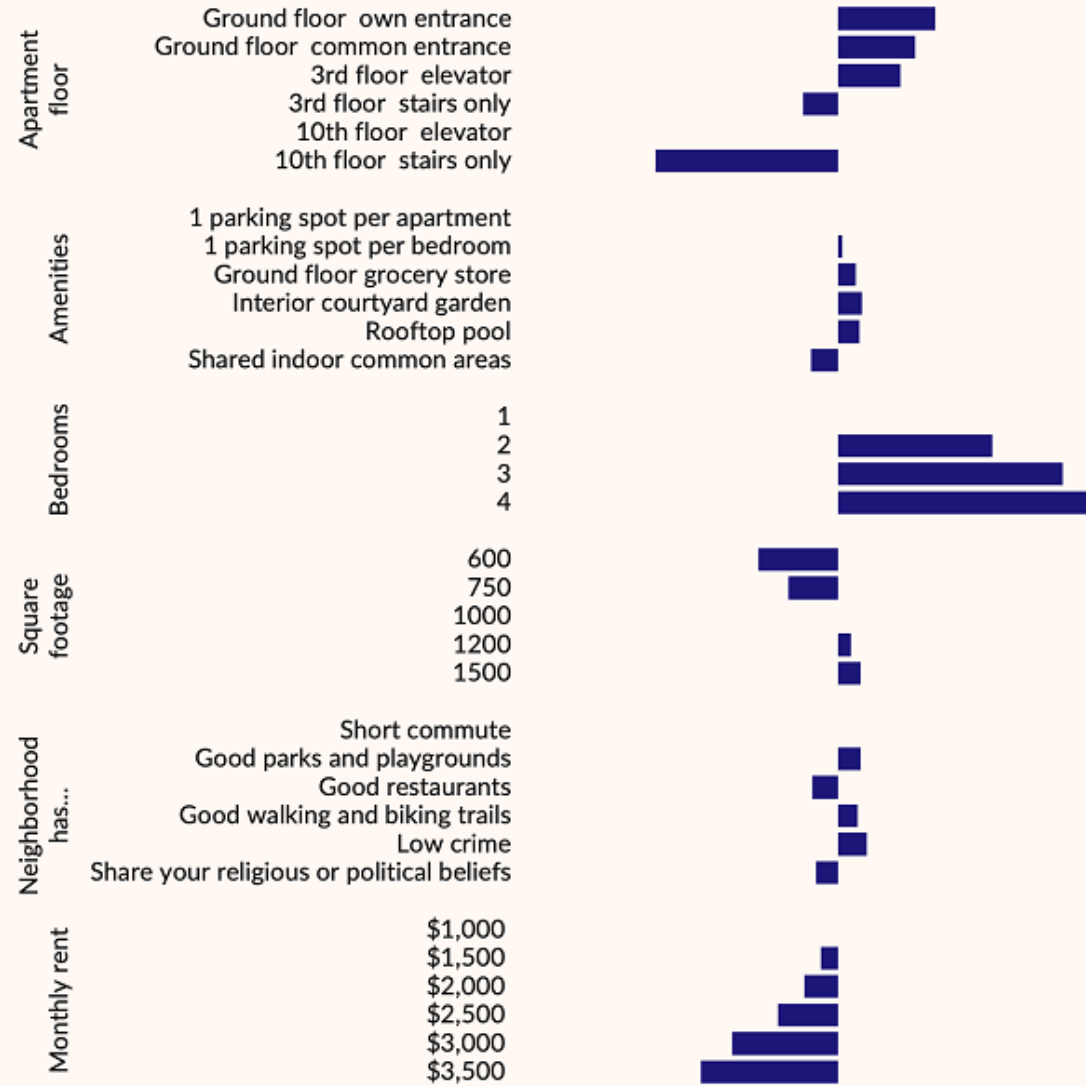

Source: IFS Multifamily Housing Survey, May 2025

New apartments have fewer bedrooms

% of occupied apartments in buildings with 20+ units as of 2023, by decade of unit construction

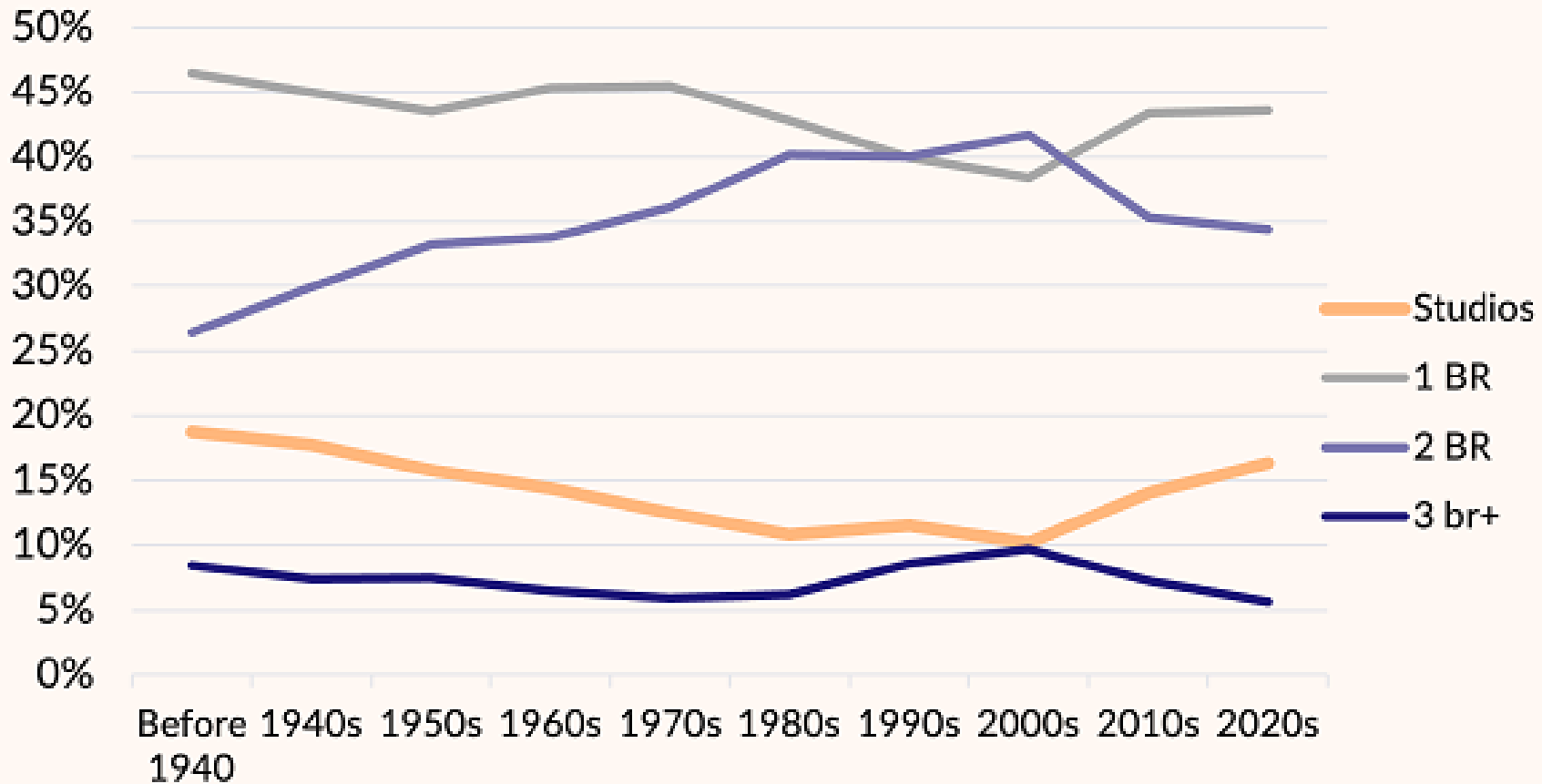

Source: 2023 American Community Survey, queried in IPUMS



New Units by Bed Type





NWA Vacancy Rates by Bedrooms

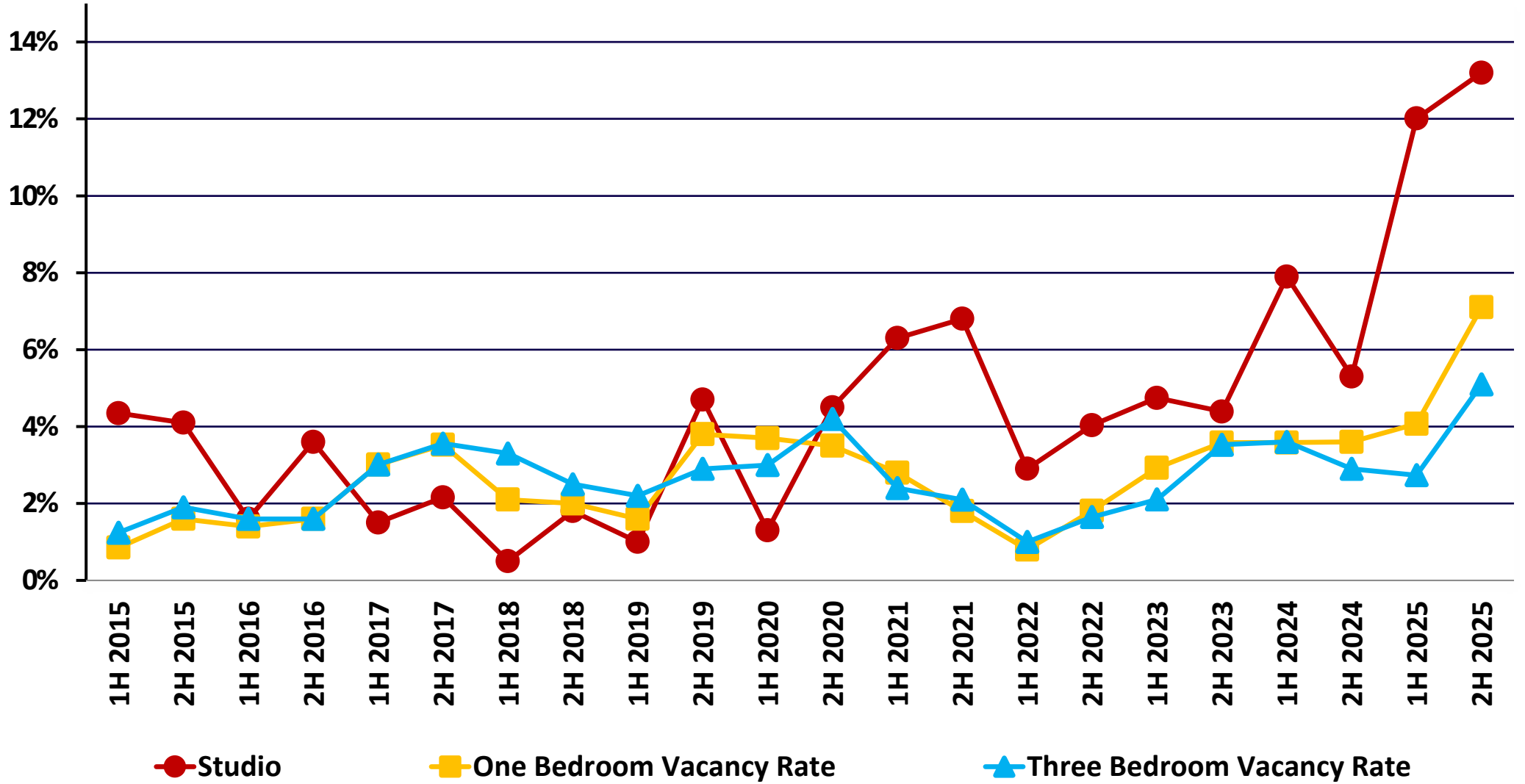
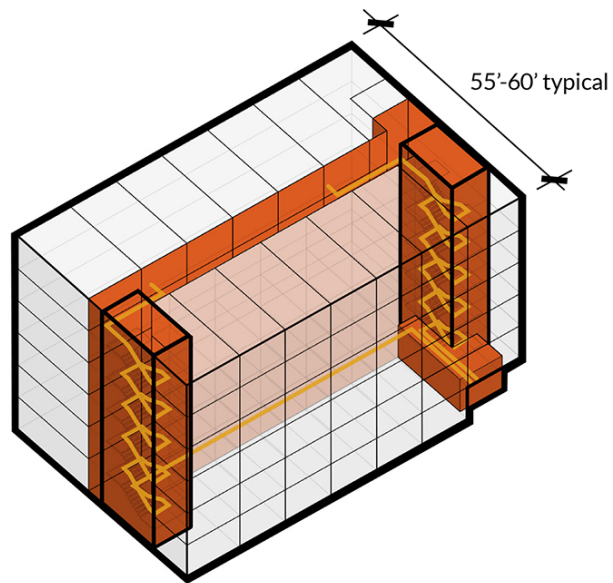
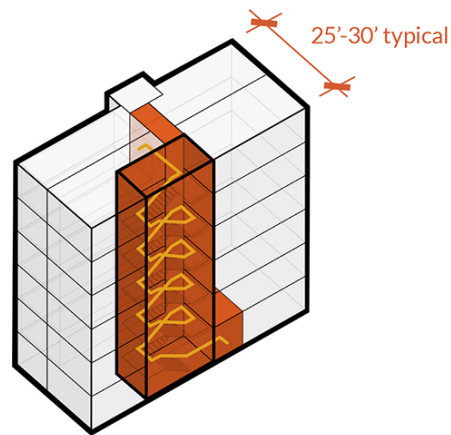

Figure 1
Building Codes Limit Small Apartment Building Designs in Much of the U.S.

Single-stair design is allowed in 3-story buildings, but 4-to-6-story buildings must have two staircases and a corridor



Double-loaded corridor six-story apartment building



Single-stair six-story apartment building, currently allowed in Seattle

Source: SAR+ Architects

© 2025 The Pew Charitable Trusts

Figure 2

Single-Stair Buildings Can Improve Ventilation and Increase the Amount of Daylight

This rendering shows air circulation and daylight coming through the windows of a 6-story building currently allowed in Seattle

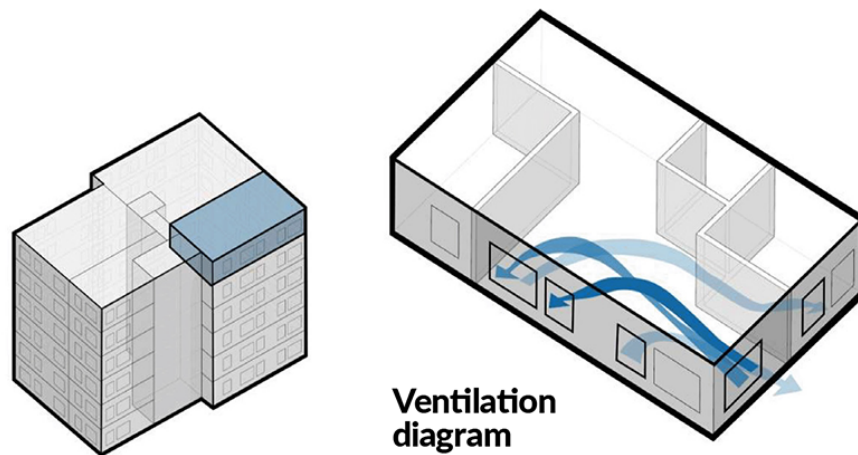

Ventilation diagram

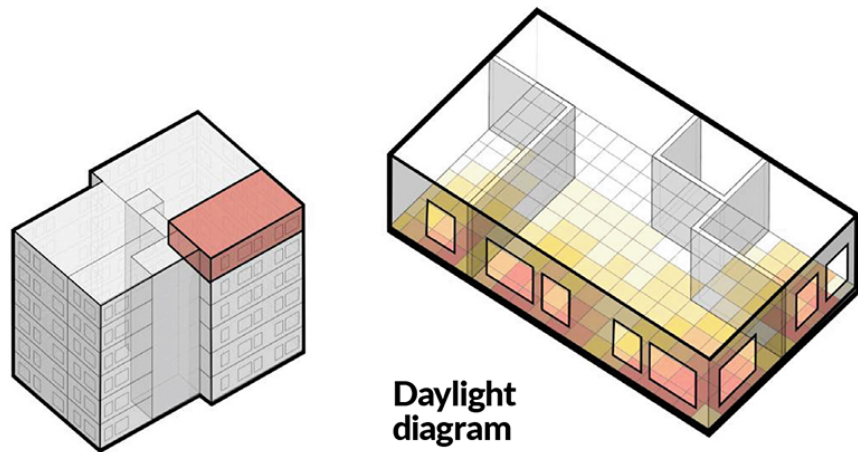

Daylight diagram

source: SAR+ Architects

© 2025 The Pew Charitable Trusts

Commercial Building Permit Values

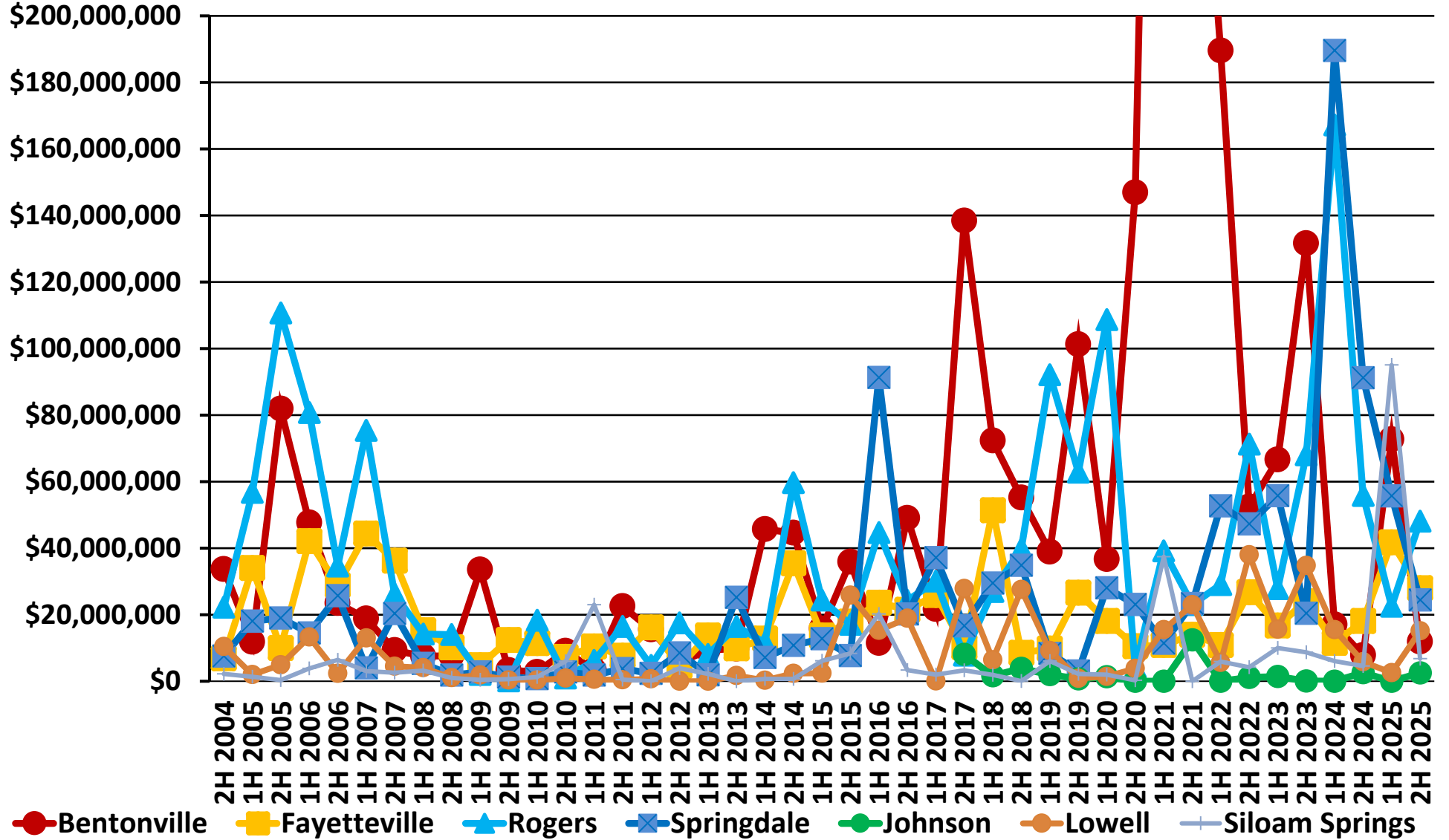

Northwest Arkansas Available Square Footage

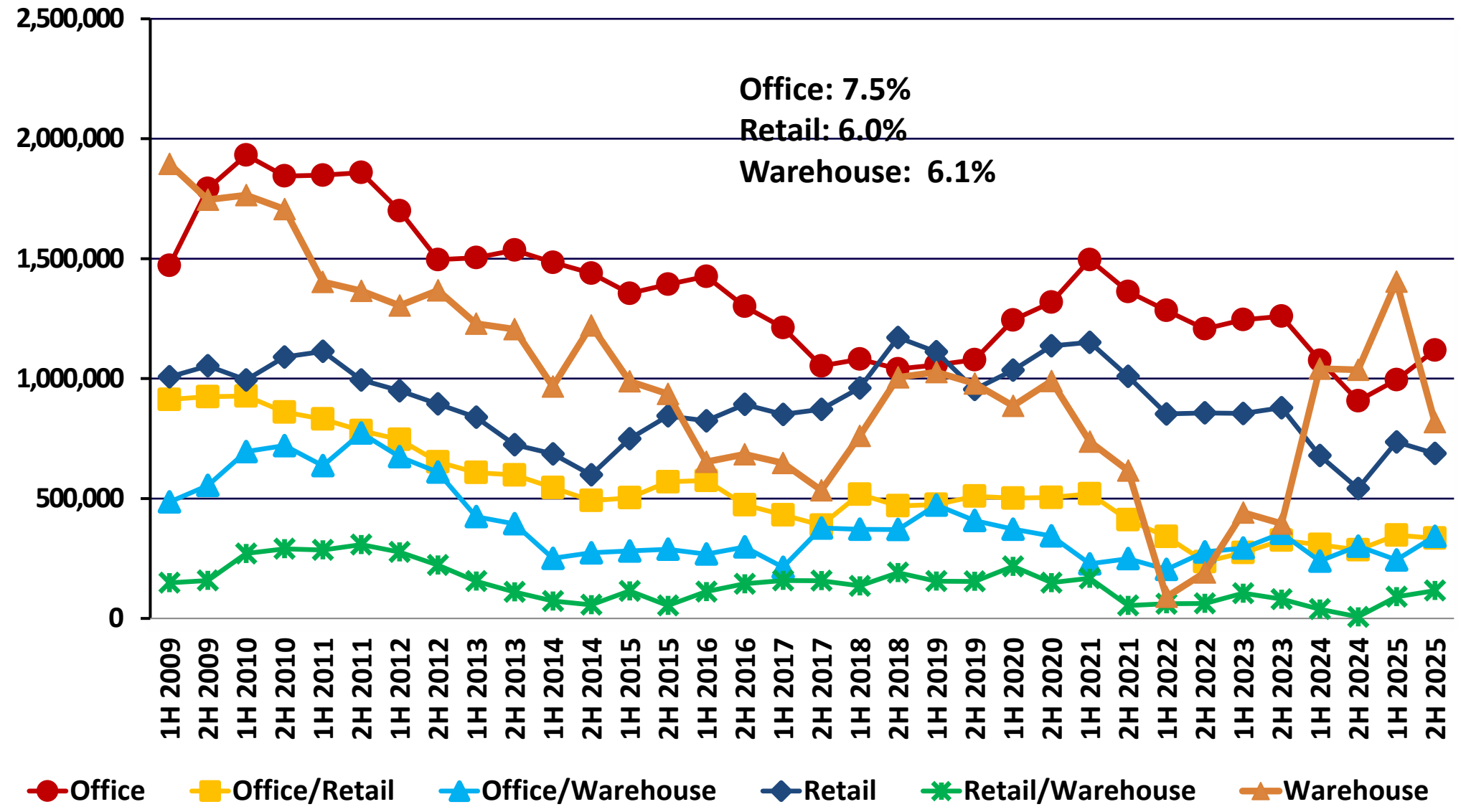

WALTON

Questions and Comments?

Contact at mjebaraj@walton.uark.edu

Phone: 479-575-4151

Twitter: @MervinJebaraj



UNIVERSITY OF
ARKANSAS